

A 头部、外装置部件(1)/ Frame miscellaneous cover components(1)

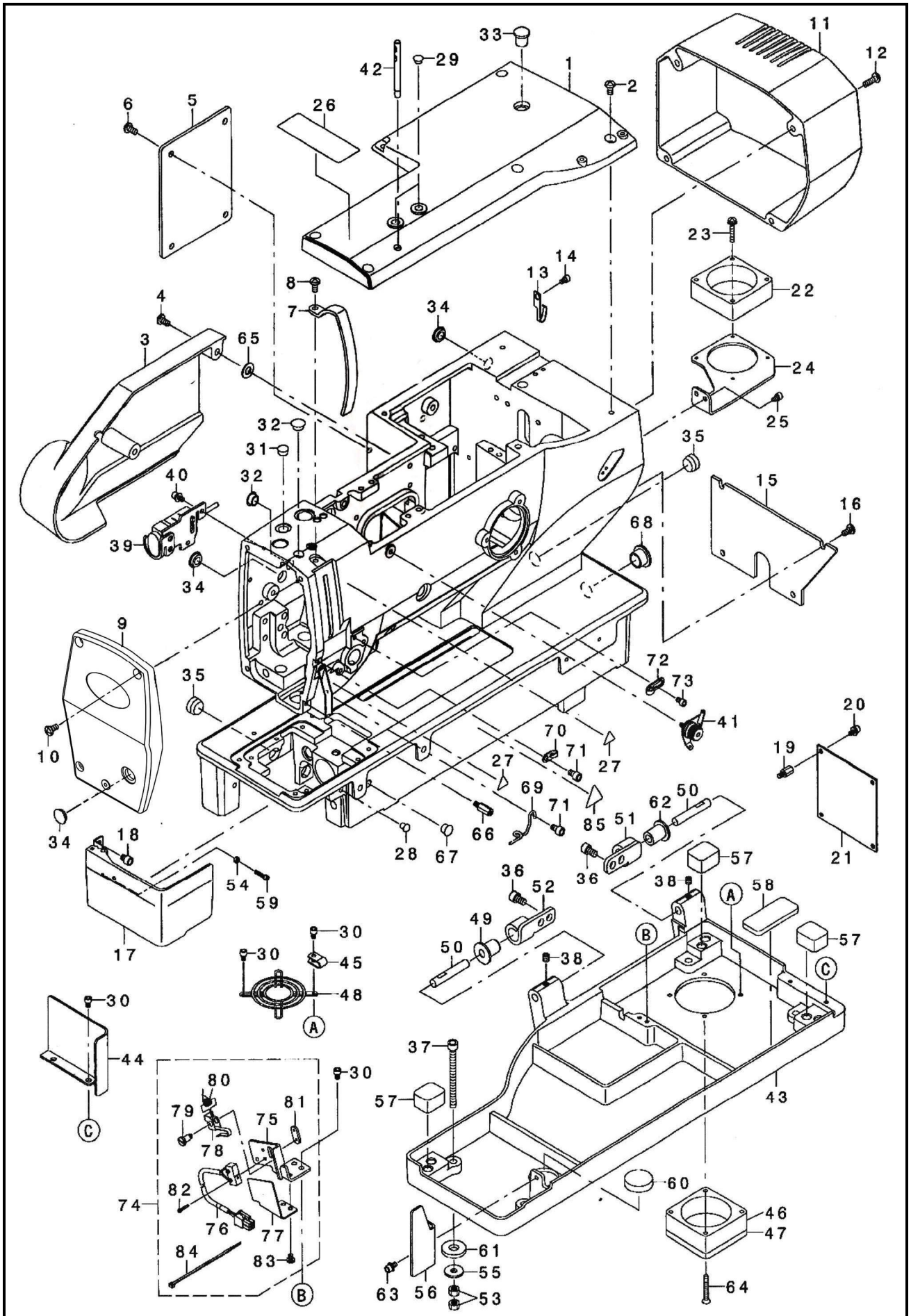

A、头部、外装置部件(1)/ Frame miscellaneous cover components(1)

参照号	零部件序号	数量	零部件名称	NAME OF PARTS	RM
1	CS79004153	1	上盖	UPPER COCVER	
2	CS04051055	6	螺钉 M5X10	SCREW, PAN M5X10	
3	CS79004154	1	左盖板	LDFT COCVER	
4	CS04051055	2	螺钉 M5X10	SCREW, PAN M5X10	
5	CS79004155	1	左盖板 B	LDFT COCVER B	
6	CS04051055	4	螺钉 M5X10	SCREW, PAN M5X10	
7	CS79004157	1	挑线杆防护罩	THREAD TAKE UP LEVER COVER	
8	CS04051055	1	螺钉 M5X10	SCREW, PAN M5X10	
9	CS79004156	1	前盖板	FRONT COVER	
10	CS04051055	3	螺钉 M5X10	SCREW, PAN M5X10	
11	CS79004159	1	马达罩壳	MOTOR COVER	
12	CS04051655	4	螺钉 M5X16	SCREW, PAN M5X16	
13	CS79030409	1	油管固定架	LUVRICATING OIL WICK STOPPER	
14	CS06040602	1	螺钉 M4X6	SCREW, PAN M4X6	
15	CS79004161	1	后盖板	REAR COVER	
16	CS04051055	4	螺钉 M5X10	SCREW, PAN M5X10	
17	CS79000956	1	旋梭防护板	HOOK OIL SHIELD COVER COMPL	
18	CS06050652	2	螺钉 M5X6	SCREW, PAN M5X6	
19	CS00033900	4	定位螺钉	STUD	
20	CS06040892	4	螺钉组件	SCREW	
21	CS79003422	1	中基板组件	INT PCB ASS' Y	
22	CS79005402	1	电路板风扇	HEAD FAN MOTOR A ASS' Y	
23	CS04042581	2	螺钉组件	SCREW	
24	CS79004367	1	风扇固定板	FAN FITTING PLATE	
25	CS06040602	2	螺钉 M4X6	SCREW, PAN M4X6	
26	CS03013000	1	安全标签	SAFETY LABEL	
27	CS03002000	2	注意标签	ATTENTION SEAL	
28	CS00550604	1	橡皮塞 5.5	PUBBER CAP, 5.5	
29	CS00750404	2	橡皮塞 7.5	PUBBER CAP, 7.5	
30	CS06040602	6	螺钉 M4X6	SCREW, PAN M4X6	
31	CS00950806	1	橡皮塞 9.5	PUBBER CAP, 9.5	
32	CS01050504	2	橡皮塞 10.5	PUBBER CAP, 10.5	
33	CS01120804	1	橡皮塞 11.2	PUBBER CAP, 11.2	
34	CS01250406	3	橡皮塞 12.5	PUBBER CAP, 12.5	
35	CS01550902	2	橡皮塞 15.5	PUBBER CAP, 15.5	
36	CS06061002	4	螺钉 M6X10	SCREW, PAN M6X10	
37	CS06067052	4	螺钉 M6X70	BOLT, SOCKET M6X70	
38	CS08060612	2	螺钉 M6X6	SET SCREW, M6X6	
39	CS79002354	1	开关组件	SWITCH ASM	
40	CS06040892	2	螺钉 M4X8	SCREW, PAN M4X8	
41	CS79028764	1	张力控制组件	PRE-TENSION CONTROLLER ASM	
42	CS79002504	1	过线轴	THREAD GUIDE BAR	
43	CS79004158	1	油盘	BED BASE	
44	CS79004160	1	底座盖板	BED REAR COVER	
45	CS00015000	1	线夹	CABLE CLAMP	
46	CS79005403	1	油盘风扇	HEAD FAN	
47	CS00005500	1	过滤器	FILTER	
48	CS00003800	1	风扇挡板	FINGER GUARD	
49	CS79006314	1	铰链套	HINGE BUSH	
50	CS79000604	2	铰链销	HINGE PIN	
51	CS79000406	1	铰链板 A	HINGE PLATE, A	
52	CS79000505	1	铰链板 B	HINGE PLATE, B	
53	CS06060001	8	螺母 M6	NUT M6	
54	CS06030001	1	螺母 M3X0.5	NUT M3X0.5	
55	CS00612056	4	垫片 6.1X18.5X2	WAOHER 6.1X18.5X2	
56	CS79043303	1	防油罩	OIL SHIELD	
57	CS79008977	3	橡胶垫 C	RUBBER C	
58	CS79008978	1	橡胶垫板 D	RUBBER D	
59	CS06031402	1	螺钉	SCREW	
60	CS02002855	1	橡胶	Z STOPPER RUBBER	

A、头部、外装置部件(1)/ Frame miscellaneous cover components(1)

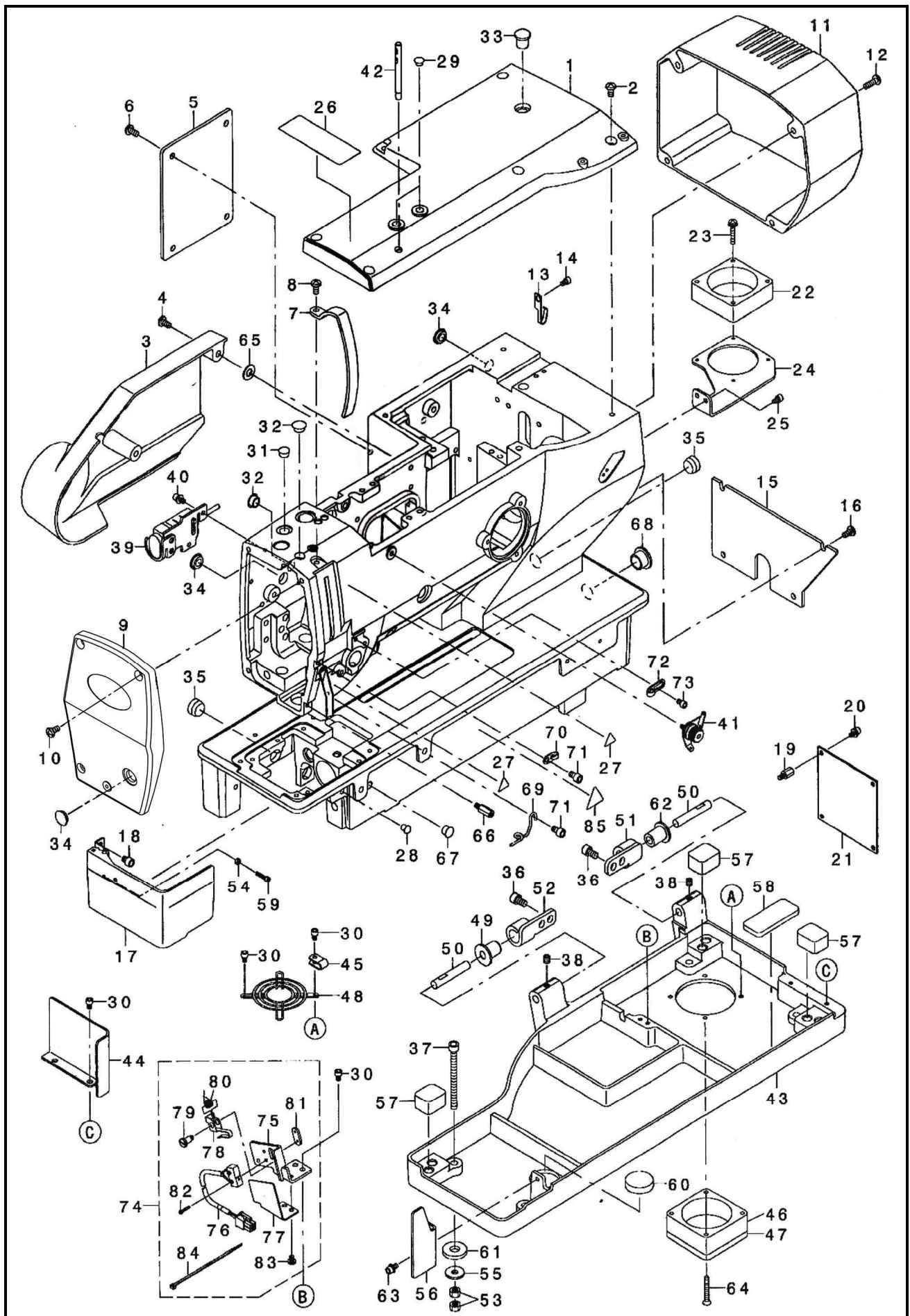

A、头部、外装置部件(1)/ Frame miscellaneous cover components(1)

参照号	零部件序号	数量	零部件名称	NAME OF PARTS	RM
61	CS06055555	4	橡胶垫片 B	RUBBER CUSHION (B)	
62	CS79000703	1	橡胶铰链	LUBRICATING OIL WICK STOPPER	
63	CS06040892	1	螺钉 M4X10	SCREW, PAN M4X10	
64	CS01043001	2	螺钉 M4X30	SCREW, PAN M4X30	
65	CS01116804	2	橡胶垫片 C	RUBBER CUSHION (C)	
66	CS03724715	1	加长螺钉	VCS STUD A	
67	CS00850604	1	橡皮塞	PUBBER PLUG	
68	CS01150490	1	橡皮塞	PUBBER PLUG	
69	CS79005405	1	过线钩	NEEDLE BAR THREAD GUIDE	
70	CS79022208	1	左线钩	TAKE-UP THREAD GUIDE B	
71	CS06050802	2	螺钉 M5X8	SCREW, PAN M5X8	
72	CS79009037	1	右线钩	TAKE-UP THREAD GUIDE A	
73	CS06040602	1	螺钉 M4X6	SCREW, PAN M4X6	
74	CS79003495	1	安全开关组件	SAFETY SWITCH ASS' Y	
75	CS79016603	1	安全开关座	SAFETY SW BASE	
76	CS79003496	1	电线	SAFETY SWITSH CORD ASS' Y	
77	CS79016900	1	安全开关盖板	SAFETY SWITSH XOVER	
78	CS79038109	1	安全开关臂	SAFETY SWITSH ARM	
79	CS79038307	1	轴位螺钉	SAFETY SWITSH ARM SHAFT	
80	CS79038208	1	安全开关弹簧	SAFETY SWITSH SPRING	
81	CS79038406	1	安全开关螺母	SAFETY SWITSH NUT	
82	CS04021201	2	螺钉 M2X12	SCREW, PAN M2X12	
83	CS07090520	2	螺钉 SM9/64" -40	SCREW, PAN SM9/64" -40	
84	CS09500B01	1	固定带	CABLE BAND	
85	CS03002000	1	注意标签	ATTENTION LABEL	

B、头部、外装置部件(2)/ Frame miscellaneous cover components(2)

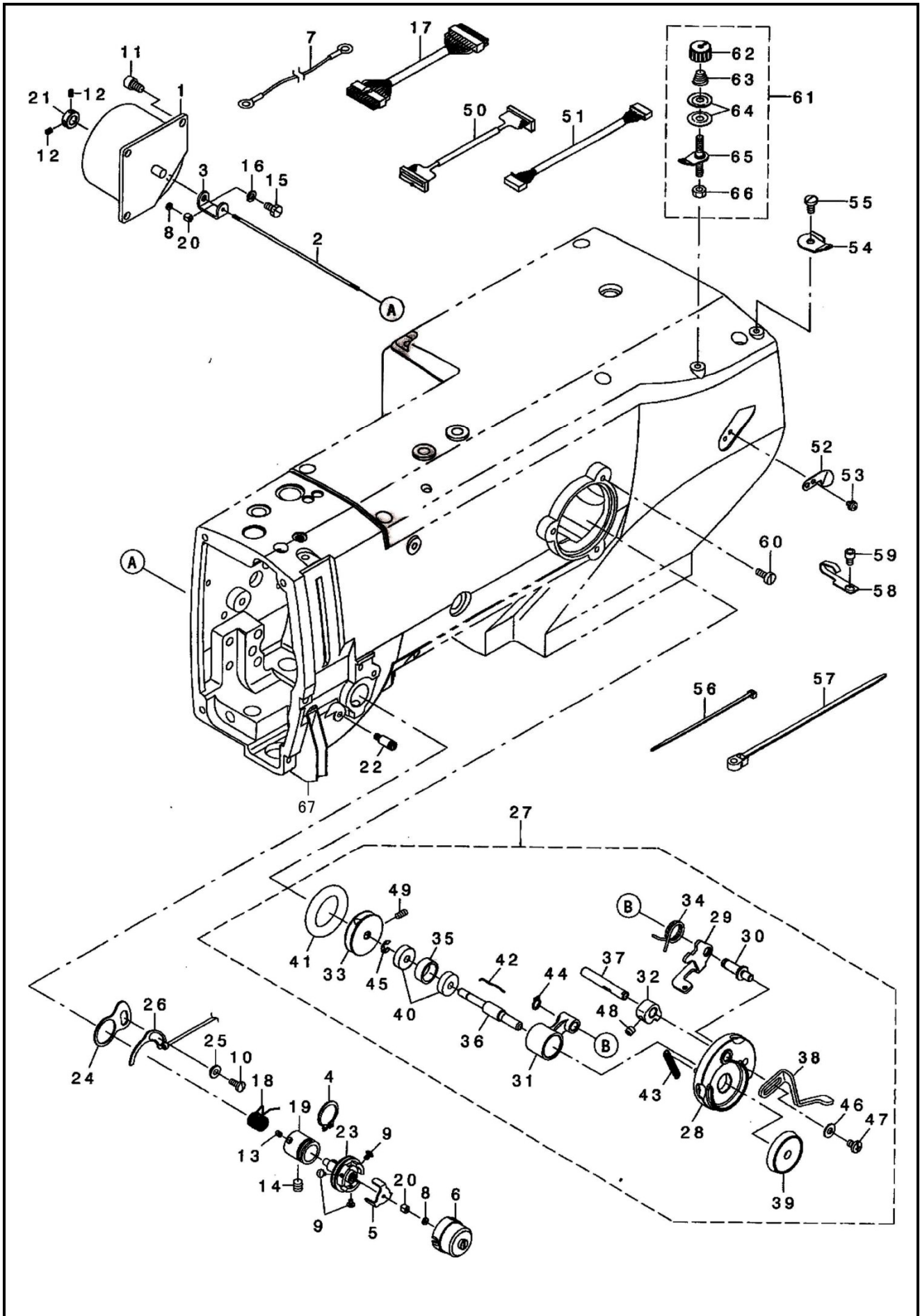

B、头部、外装置部件(2)/ Frame miscellaneous cover components(2)

参照号	零部件序号	数量	零部件名称	NAME OF PARTS	RM
1	CS79006261	1	夹线电磁铁组件	ASSY AT SOLENOID	
2	CS79006263	1	拉杆	AT SHAFT	
3	CS79006264	1	松线支架	AT SHAFT HOLDER	
4	CS01700001	1	轴用挡圈 C15	RETAINING RING, EXTERNAL C15	
5	CS79006269	1	松线止动卡盘	DISK STOPPER	
6	CS79006271	1	夹线器帽	DISK STOPPER HOLDER CAP	
7	CS09019580	1	接地线	EARTH CABLE ASM	
8	CS06020001	2	螺母 M2	NUT M2	
9	CS00860400	3	螺钉 2. 6X4	SCREW, PAN M2. 6X4	
10	CS06040860	1	螺钉 M4X8	SCREW, PAN M4X8	
11	CS06050802	3	螺钉 M5X8	SCREW, PAN M5X8	
12	CS08030412	2	螺钉 M3X4	SET SCREW, SOCKET (FT) M3X4	
13	CS08030450	1	螺钉 M3X4	SET SCREW, (CP) M3X4	
14	CS08060612	1	螺钉 M6X6	SET SCREW, SOCKET (FT) M6X6	
15	CS09040800	1	螺栓 M4X8	BOLT, SOCKET M4X8	
16	CS00410002	1	弹簧垫片 M4	WASHER, SPRING M4	
17	CS79005397	1	电机连接线	MAIN INT XORD A ASS' Y	
18	CS79006104	1	挑线弹簧	THREAD TAKE-UP SPRING	
19	CS79006268	1	夹线座	TENSION BRACKET	
20	CS79006270	2	卡圈	THREAD TENSION SHAFT COLLAR	
21	CS79055402	1	定位环	THRUST COLLAR	
22	CS79004252	1	螺柱	UTT SUSPENSION SCREW 9	
23	CS79006265	1	紧线器组件	ASSY THREAD TENSION POST	
24	CS02702210	1	导板	GUIDE PLATE	
25	CS02703210	1	尼龙垫片	BUSHING	
26	CS79003499	1	接触片	THREAD BREAK DETECTOR A	
27	CS79011143	1	绕线器组件	ASSY BTW	
28	CS79060109	1	绕线基座	BTW BASE	
29	CS79060208	1	控制板	BTW CAM PLATE	
30	CS79060307	1	绕线定位轴	BTW BASE SHAFT	
31	CS79060406	1	绕线转动曲柄	BTW SHAFT BASE	
32	CS79060505	1	转动卡头	BTW CAM LEVER	
33	CS79060604	1	绕线驱动轮	BTW WHEEL	
34	CS79011144	1	弹簧	BTW TORSION SPRING	
35	CS79060802	1	挡圈	BTW BEARING SPACER	
36	CS79011145	1	绕线器轴	BTW SHAFT	
37	CS79011146	1	梭芯压杆轴	BTW LEVER SHAFT	
38	CS79021933	1	梭芯压杆	BTW LEVER	
39	CS79061206	1	梭芯垫片	BTW SPACER	
40	CS79061305	2	轴承	BALL BEARING	
41	CS79061503	1	橡皮圈	BOBBIN WINDER RUBBER BAND	
42	CS79061602	1	梭芯弹簧	BOBBIN SPRING	
43	CS79061701	1	弹簧	BTW SPRING	
44	CS00560711	1	轴用挡圈 C5	RETAINING RING, EXTERNAL C5	
45	CS00400000	1	挡圈 E4	RETAINING RING E4	
46	CS00450826	1	平垫圈 4. 5X10X0. 8	WAOHER PLAIN 6. 1X18. 5X2	
47	CS05040655	1	螺钉 M2X12	SCREW, PAN M2X12	
48	CS08050502	1	螺钉 M5X5	SET SCREW, SOCKET (FT) M5X5	
49	CS08040802	2	螺钉 M4X8	SET SCREW, SOCKET (FT) M4X8	
50	CS79005398	1	信号连接线	MAIN INT CORD B ASS' Y	
51	CS79005399	1	电磁铁连接线	MAIN INT CORD D ASS' Y	
52	CS79002300	1	切线刀	THREAD CUTTER	
53	CS04030581	2	切线刀螺钉 M3X5	COMBINATION SCREW M3X5	
54	CS03162555	1	导线器	THREAD GUIDE	
55	CS07110840	1	螺钉 SM11/64” -40	SCREW SM11/64” -40	
56	CS09500B01	10	电线夹	BINDER	
57	CS00015100	2	电线夹	BINDER	
58	CS79030409	3	润滑油管固定片	LUBRICATING OIL WICK STOPPER	
59	CS06040602	3	螺钉 M4X6	SCREW, PAN M4X10	
60	CS06041050	3	螺钉 M4X10	SCREW, PAN M4X10	

B、头部、外装置部件(2)/ Frame miscellaneous cover components(2)

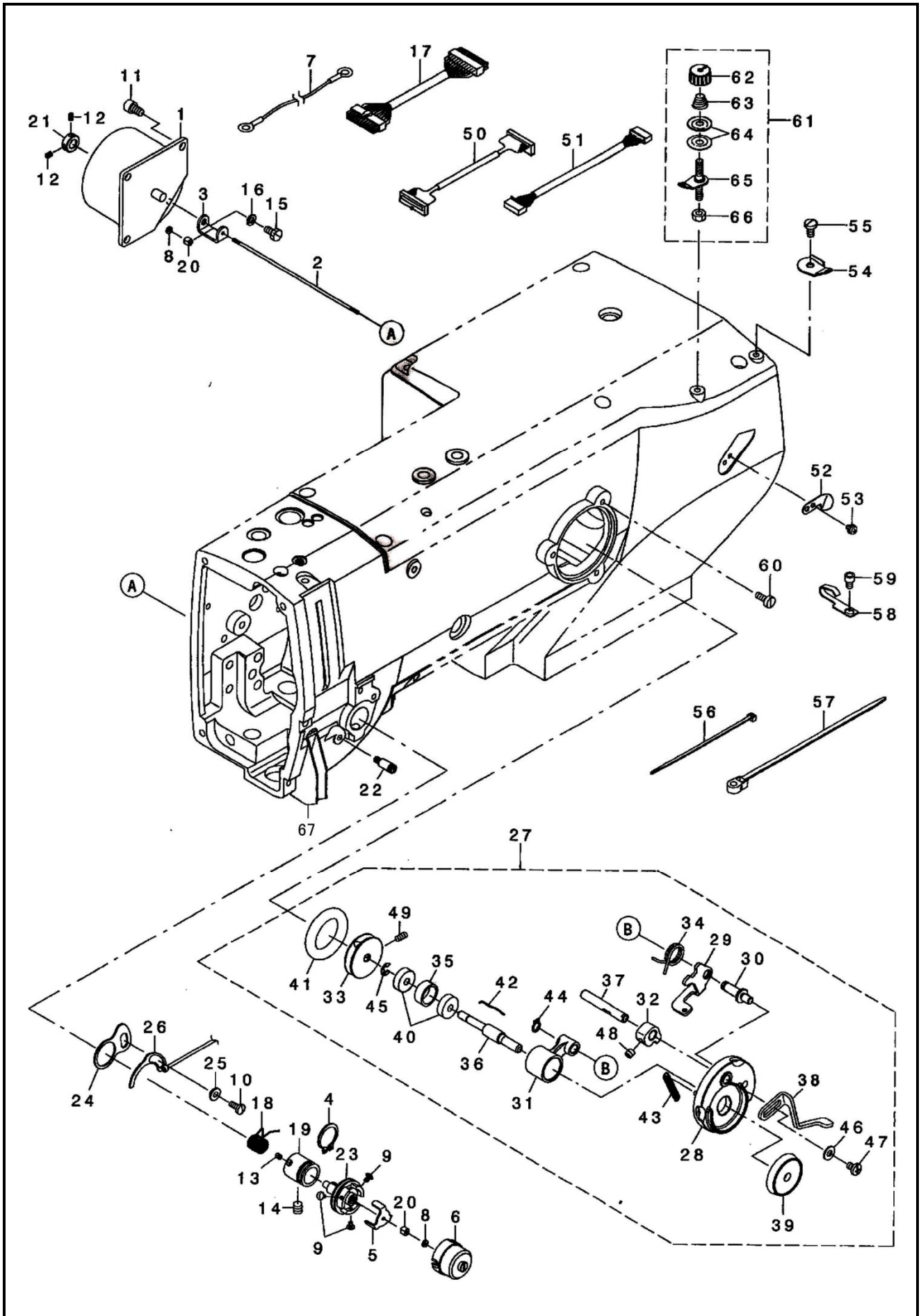

B、头部、外装置部件(2)/ Frame miscellaneous cover components(2)

参照号	零部件序号	数量	零部件名称	NAME OF PARTS	RM
61	CS79029481	1	卷线器夹线组件	BOBBIN WINDER TENSION ASSY	
62	CS79072402	1	压线螺母	TENSION NUT	
63	CS79093606	1	夹线弹簧	TENSION SPRING	
64	CS03214047	2	夹线盘	DISC, TENSION	
65	CS79029473	1	过线销组件	BOBBIN THREAD TENSION ROD ASM	
66	CS06110310	1	螺母 SM11/64" -40	NUT SM11/64" -40	
67	CS79010002	1	导线槽	THREAD GUIDE	

C、上轴部件/ Main shaft components

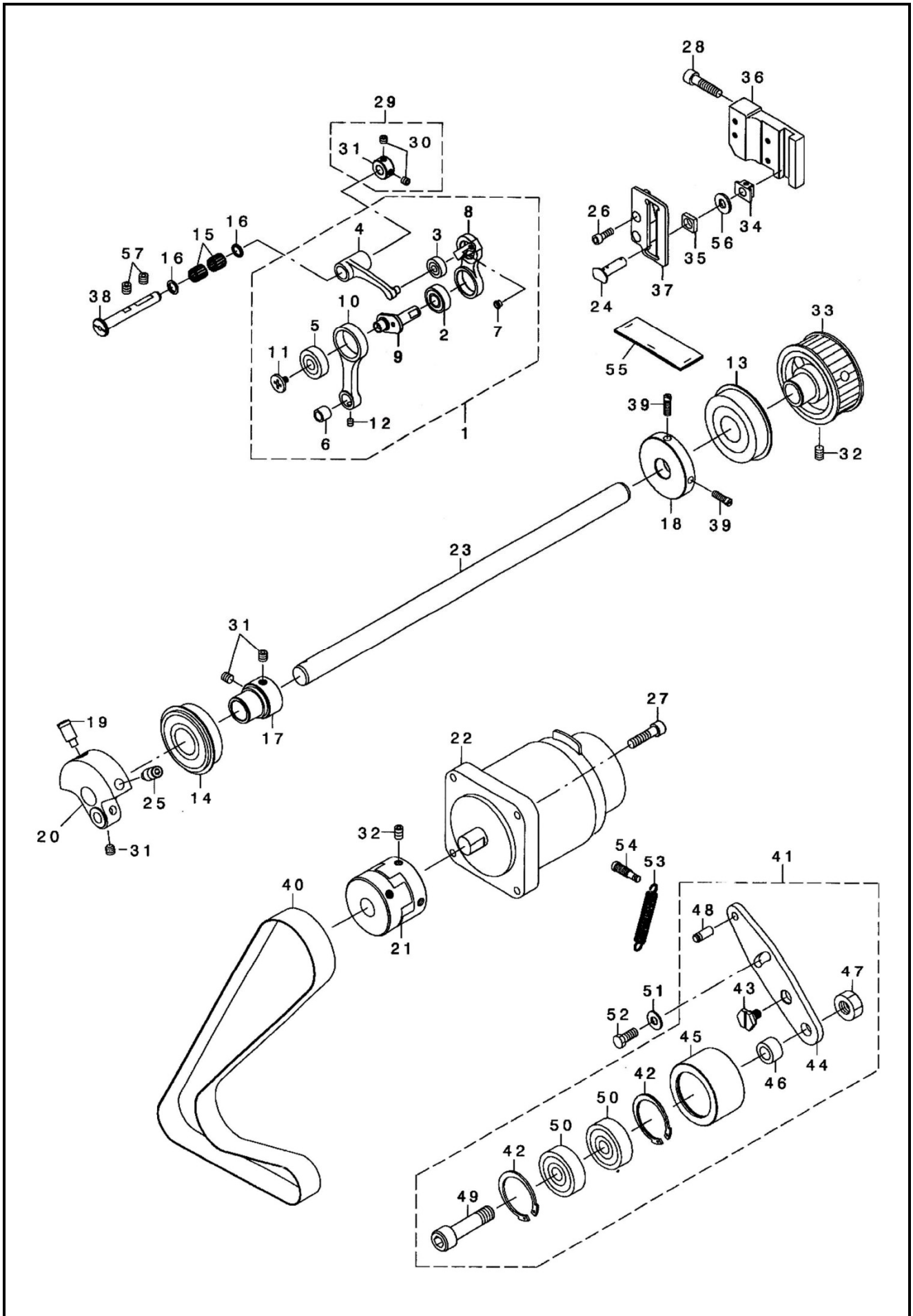

C、上轴部件/ Main shaft components

参照号	零部件序号	数量	零部件名称	NAME OF PARTS	RM
1	CS79004178	1	挑线组件	THREAD TAKE UP ASM	
2	CS01080023	1	轴承 698LB	BALL BEARING, ARDIAL 698LB	
3	CS01050018	1	轴承 605LB	BALL BEARING, ARDIAL 605LB	
4	CS79004177	1	挑线连杆	THREAD TAKE UP CRANK	
5	CS01080004	1	轴承 608	BALL BEARING, ARDIAL 608	
7	CS01908505	1	过线套	THREAD PASS BUSH	
8	CS79004173	1	挑线杆组件	LINK TAKE UP	
9	CS79004174	1	挑线曲柄	NEEDLE BAR CRANK	
10	CS79004175	1	针杆连杆组件	NEEDLE BAR CRANK ROD	
11	CS01903552	1	螺钉 SM3. 57-40L	SCREW, SM3. 57-40L	
12	CS08040412	1	螺钉 M4X4	SET SCREW, SOCKET (FT) M4X4	
13	CS01200008	1	轴承 6304Z	BALL BEARING, ARDIAL 6304Z	
14	CS01200020	1	轴承 6204	BALL BEARING, ARDIAL 6204	
15	CS03070002	2	滚针轴承	NEEDLE BEARING	
16	CS79091204	2	封油垫片	BEARING SUPPORT	
17	CS79005207	1	轴承固定套	BEARING HOLDER	
18	CS79036400	1	绕线轮	BOBBIN WINDER DRIVING WHEEL	
19	CS79004171	1	固定螺钉	COUNTER WEIGHT SCREW	
20	CS79004170	1	针杆曲柄	COUNTER WEIGHT	
21	CS79004309	1	传动连接块组件	COUPLING	
22	CS79028015	1	主轴伺服电机	AC SERVO MOTOR	
23	CS79004167	1	上轴	MAIN SHAFT	
24	CS02704208	1	滑块轴	NEEDLE CRANK SHAFT	
25	CS08081652	1	螺栓 M8X16	BOLT, SOCKET M8X16	
26	CS06041202	2	螺栓 M4X12	S OLT, SOCKET M4X12	
27	CS06052002	4	螺栓 M5X20	OLT, SOCKET M5X20	
28	CS06062502	3	螺栓 M6X25	OLT, SOCKET M6X25	
29	CS79010434	1	挡圈组件	THRUST COLLAR ASM	
30	CS08050412	2	螺钉 M5X4	SET SCREW, SOCKET (FT) M5X4	
31	CS79010435	1	紧圈	SET SCREW COLLAR	
32	CS08060812	6	螺钉 M6X8	SET SCREW, SOCKET (FT) M6X8	
33	CS79004168	1	上同步轮组件	SPROCKET A	
34	CS79004206	1	导向滑块	SQUARE BLOCK	
35	CS79008426	1	导向滑块	SQUARE BLOCK	
36	CS79006307	1	针杆导向板	SQUARE BLOCK GUIDE	
37	CS79006308	1	针杆导向板 B	SQUARE BLOCK GUIDE B	
38	CS79006300	1	挑线连杆轴	THREAD TAKE UP CTANK SHAFT	
39	CS06111440	2	螺钉 M5X8	SCREW, M5X8	
40	CS79004169	1	同步带 810-3GT-20	TIMING BELT 810-3GT-20	
41	CS79004182	1	皮带张紧轮组件	IDLER ASM	
42	CS03781518	2	孔用挡圈 C37	RETAINING RING, INTERNAL C37	
43	CS79004185	1	轴位螺钉	HINGE SCREW	
44	CS79004184	1	张力轮安装板	IDLER FIXED PLATE	
45	CS79004183	1	张力轮	IDLER PULLEY	
46	CS79010504	1	挡圈	INTERMEDIATE SPROCKET WASHER	
47	CS06100001	1	螺母 M10	NUT M10	
48	CS79050804	1	挂簧销	FEED LEVER SPRING HOOK	
49	CS06104352	1	螺栓 M10X42. 5	OLT, SOCKET M6X42. 5	
50	CS01100007	2	轴承 6300Z	BALL BEARING, ARDIAL 6300Z	
51	CS00621046	1	垫片	WASHER	
52	CS09061403	1	螺钉 M6X14	BOLT, M6X14	
53	CS79004192	1	调整弹簧	ADJUSTING SPRING	
54	CS79004179	1	挂簧螺钉	SUSPENSION SCREW	
55	CS79011517	1	润滑毡	NEEDLE BAR CRANK FELT	
56	CS79008423	1	垫片	WASHER	
57	CS08060612	6	螺钉 M6X6	SET SCREW, SOCKET (FT) M6X6	

D、下轴部件/ Hook driving shaft component

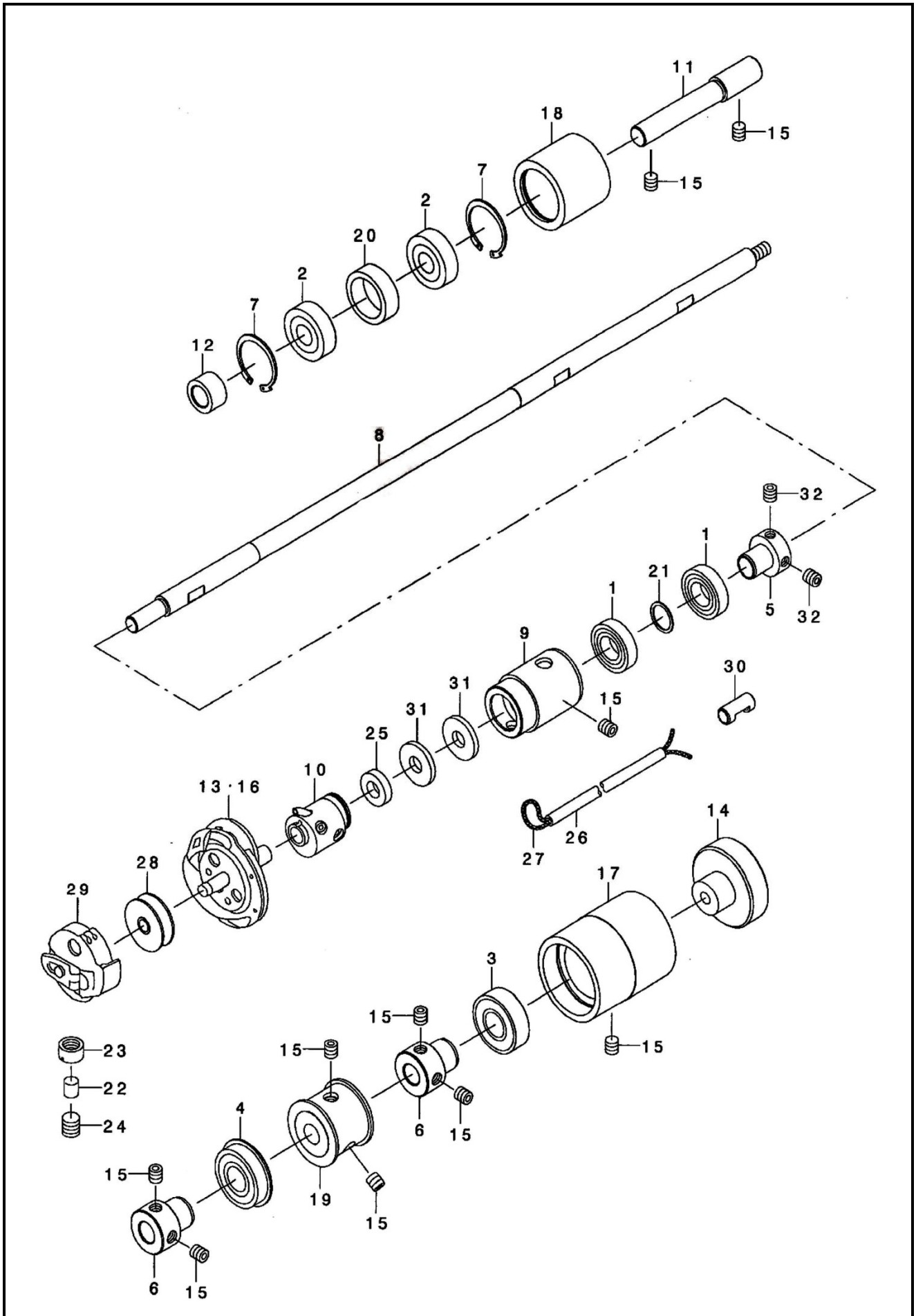

D、下轴部件/ Hook driving shaft components

参照号	零部件序号	数量	零部件名称	NAME OF PARTS	RM
1	CS01120016	1	轴承 6901LB	BALL BEARING, ARDIAL 6901LB	
2	CS01100006	1	轴承 6000V	BALL BEARING, ARDIAL 6000V	
3	CS01150002	1	轴承 6202Z	BALL BEARING, ARDIAL 6202Z	
4	CS01150015	1	轴承 6202DV	BALL BEARING, ARDIAL 6202DV	
5	CS79004188	1	轴承套	BALL BEARING BUSH	
6	CS79036204	2	轴承套	BALL BEARING BUSH	
7	CS02791218	2	孔用挡圈 C27	RETAINING RING, INTERNAL C27	
8	CS79004186	1	下轴	HOOK DRIVING SHAFT	
9	CS79004187	1	下轴前轴套	HOOK DRIVING SHAFT METAL	
10	CS79029660	1	旋梭连接套组件	HOOK SLEEVE ASM	
11	CS79010306	1	中同步轮轴	INTERMEDIATE SPROCKET SHAFT	
12	CS79010504	1	挡圈	INTERMEDIATE SPROCKET WASHER	
13	CS79029066	1	旋梭 (790)	HOOK COMPL	
14	CS08039870	1	手轮	CROWN KNOB	
15	CS08060612	10	螺钉 M6X6	SET SCREW, SOCKET (FT) M6X6	
16	CS79082065	1	旋梭 (791K)	HOOK COMPL (K)	
17	CS79004401	1	下轴后轴套	BEARING SUPPORT	
18	CS79004180	1	中同步轮	SPROCKET B	
19	CS79004181	1	下同步轮组件	SPROCKET C	
20	CS79010405	1	垫圈	INTERMEDIATE SPROCKET RING	
21	CS79006317	1	垫圈	WASHER	
22	CS79006322	1	调整杆	AD JUSTING SHAFT	
23	CS79006312	1	调整螺母	AD JUSTING NUT	
24	CS08080812	1	旋梭油量调节螺钉 M8X8	SET SCREW, SOCKET (FT) M8X8	
25	CS79006320	1	油毡	FELT	
26	CS79030007	1	油管	TUBE	
27	CS02020000	1	油线	OIL WICK	
28	CS01811771	1	梭芯	BOBBIN	
29	CS79029769	1	梭壳	BOBBIN CASE ASM	
30	CS79006321	1	油量控制架	PIPE	
31	CS79011355	2	油毡	OIL FILTER	
32	CS08050502	2	螺钉 M5X5	SET SCREW, SOCKET (FT) M5X5	

E、压脚、送料部件/ Presser feed components

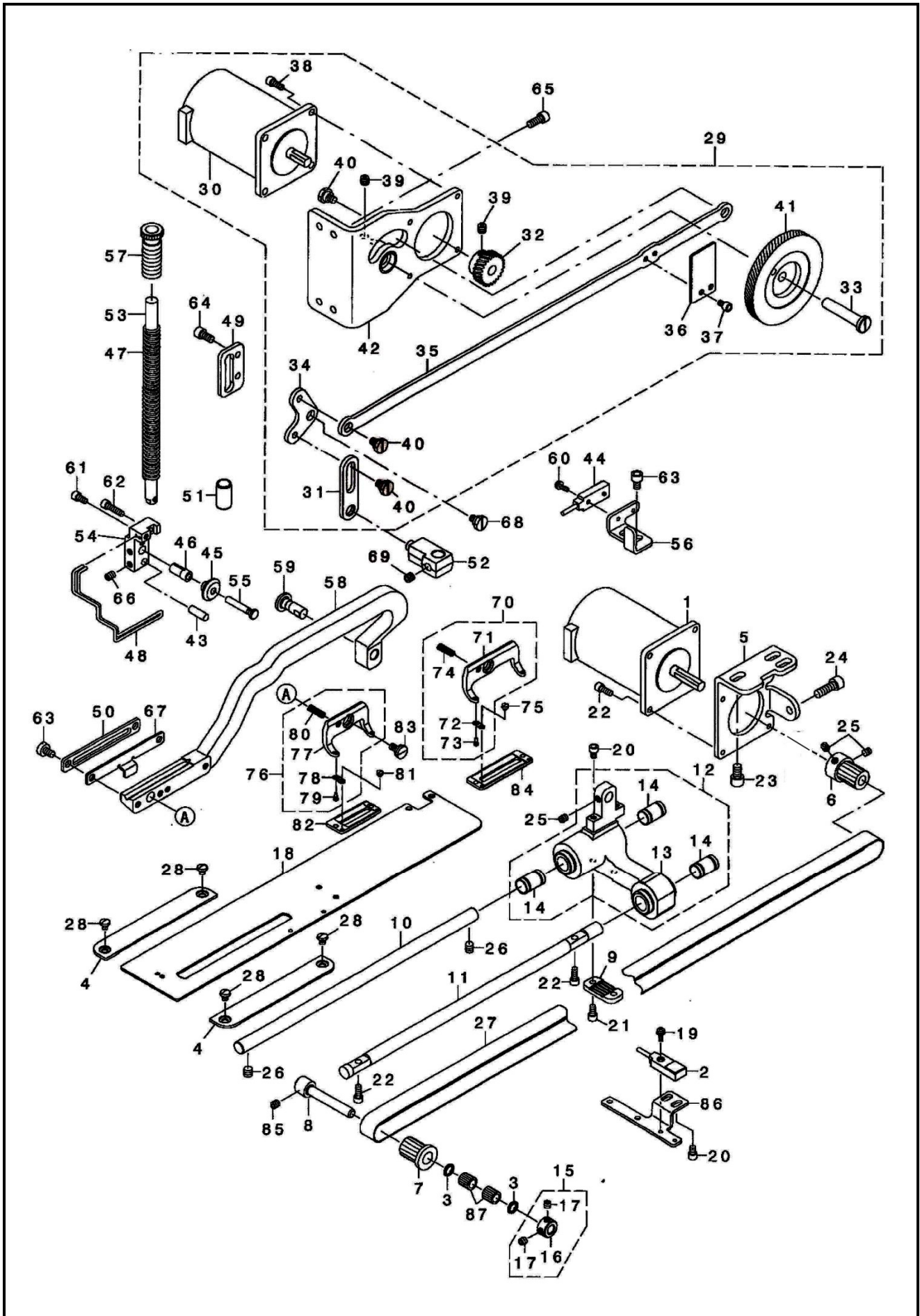

E、压脚、送料部件/ Presser feed components

参照号	零部件序号	数量	零部件名称	NAME OF PARTS	RM
1	CS79005372	1	送布马达	PEED MOTOR ASS' Y	
2	CS79005378	1	送布传感器	PEED SENSOR ASS' Y	
3	CS79091204	2	封油垫片	BEARING SUPPORT	
4	CS79009202	2	固定板	THROAT PLATE BASE COVER	
5	CS79004194	1	送料步进电机固定架	MOTOR BRACKET	
6	CS79004196	1	同步轮组件 B	PULLEY B	
7	CS79004197	1	同步轮组件 C	PULLEY C	
8	CS79004198	1	同步轮轴	SUPPORT SHAFT	
9	CS79004200	1	固定板	TIMING BELT HOLDER	
10	CS79004201	1	支架轴	FEED SHAFT	
11	CS79022121	1	送布支架导向轴	FEED GUIDE SHAFT	
12	CS79004203	1	送布支架组件	FEED BASE ASM	
13	CS79004204	1	送布支架	FEED BASE	
14	CS07100002	3	送布支架轴承	SLIDE BEARING	
15	CS79010434	1	挡圈组件	THRUST COLLAR ASM	
16	CS79010435	1	挡圈	SET SCREW COLLAR	
17	CS08050412	2	螺钉 M5X4	SCREW, PAN M5X4	
18	CS79004205	1	送料板	FEED PLATE	
19	CS04031081	1	螺钉(带垫圈) 3X10	SCREW, PAN(S/P WASHER) M3X10	
20	CS06040602	4	螺栓 M4X6	OLT, SOCKET M4X6	
21	CS06040802	2	螺栓 M4X8	OLT, SOCKET M4X8	
22	CS06041002	6	螺栓 M4X10	OLT, SOCKET M4X10	
23	CS06061002	3	螺栓 M6X10	OLT, SOCKET M6X10	
24	CS06061802	1	螺栓 M6X18	OLT, SOCKET M6X18	
25	CS08050502	3	螺钉 M5X5	SET SCREW, SOCKET (FT) M5X5	
26	CS08060612	2	螺钉 M6X6	SET SCREW, SOCKET (FT) M6X6	
27	CS79004199	1	同步带 708-3GT-15	TIMING BELT708-3GT-15	
28	CS05040550	4	螺钉 M4X5	SCREW, PAN M4X5	
29	CS79004266	1	抬压脚组件	ASSY PBL GEAR MODULE	
30	CS79005373	1	抬压脚步进电机	CLAMP MOTOR ASS' Y	
31	CS79004273	1	压脚导向连接板	PBL FRONT LINK	
32	CS79004291	1	压脚升降齿轮 S	PBL GEAR S	
33	CS79004275	1	齿轮轴	PBL GEAR SHAFT	
34	CS79004282	1	压脚升降摆动板	PBL L LINK	
35	CS79004270	1	压脚升降拉杆	PBL LONG ROD	
36	CS79004278	1	传感器板	PBL SENOR PLATE	
37	CS06040602	2	螺栓 M4X6	OLT, SOCKET M4X6	
38	CS06041002	4	螺栓 M4X10	OLT, SOCKET M4X10	
39	CS08060552	5	螺钉 M6X5	SCREW, PAN M6X5	
40	CS00800326	4	轴位螺钉 8	SHOULDER SCREW D8 H3.2	
41	CS79004289	1	压脚升降齿轮 A 组件	ASSY PBL GEARL	
42	CS79004267	1	压脚电机安装板组件	ASSY PBL MOTOR BASE	
43	CS79059008	1	压脚支架固定轴	PIN, SHORT	
44	CS79005379	1	传感器	CLAMP SENSOR ASS' Y	
45	CS79019551	1	滑轮	SLIDE ROLLER	
46	CS79026308	1	衬套	COLLAR	
47	CS79004281	1	压脚杆弹簧	PBL COIL SPRING	
48	CS79004285	1	压护簧	PBL FINGER GUARD	
49	CS79004276	1	压脚杆滑槽	PBL GUIDE	
50	CS79004280	1	压脚前后送料导向板	PBL LIFTING PLATE	
51	CS79004279	1	压脚杆套	PBL METAL	
52	CS79004274	1	压脚杆升降支架	PBL POSITION BRACKET	
53	CS79004271	1	压脚轴	PBL PRESSER BAR	
54	CS79004283	1	滑轮支架	PBL POLLER BASE	
55	CS79004286	1	滑轮轴	PBL ROLLER SHAFT	
56	CS79004277	1	传感器安装板	PBL SENSOR BASE	
57	CS79004272	1	弹簧调节螺母	PBL SPRING REGULATOR	
58	CS79004287	1	压脚支架	PBL WORK CLAMP ARM	
59	CS79004288	1	曲柄轴	PBL WORK CLAMP ARM SHAFT	
60	CS04031081	1	螺钉 M3X10	SCREW, PAN M3X10	

E、压脚、送料部件/ Presser feed components

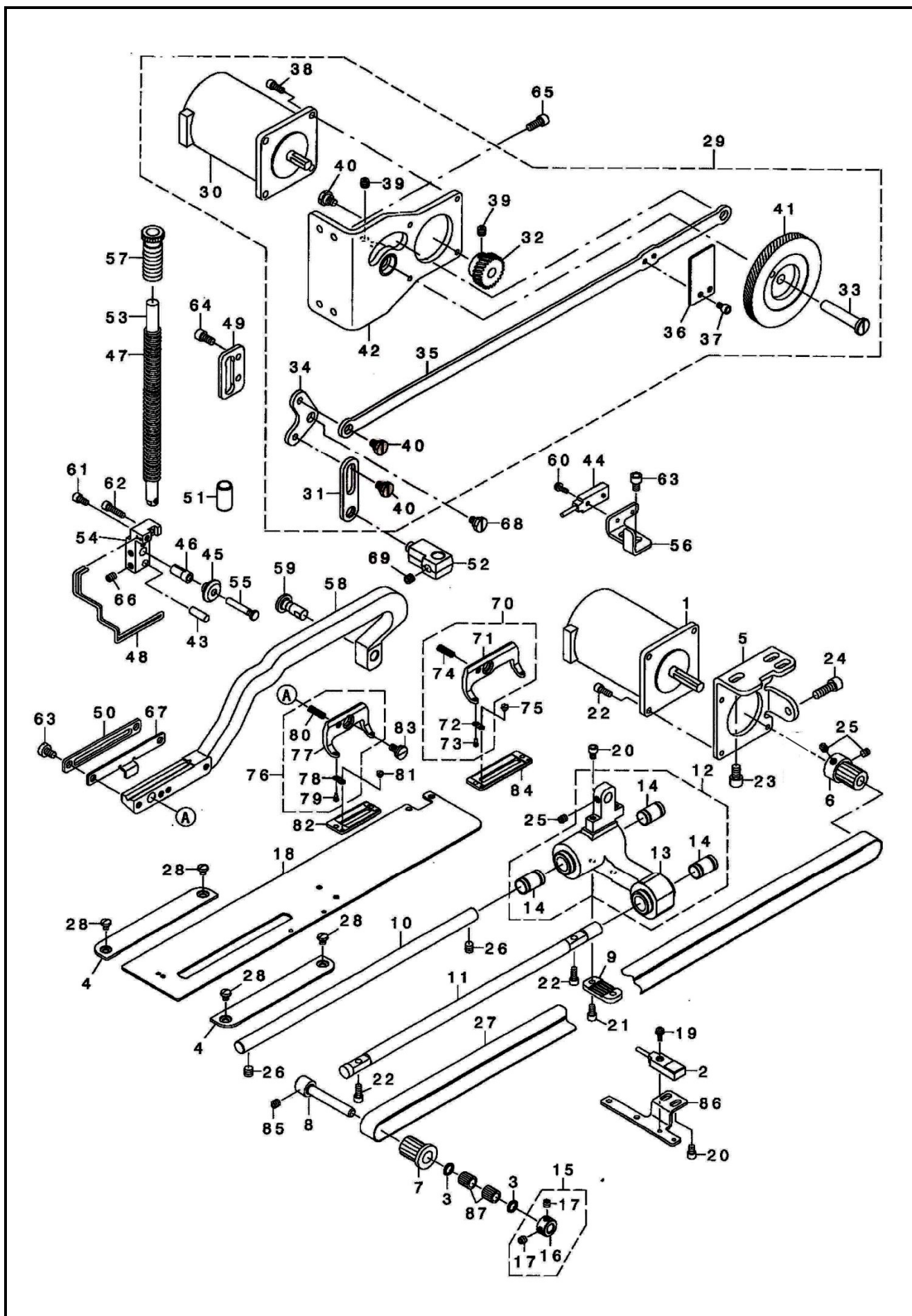

E、压脚、送料部件/ Presser feed components

参照号	零部件序号	数量	零部件名称	NAME OF PARTS	RM
61	CS06040802	1	螺栓 M4X8	OLT, SOCKET M4X8	
62	CS06041602	1	螺栓 M4X16	OLT, SOCKET M4X16	
63	CS06050800	2	螺钉 M5X8	SCREW, PAN M5X8	
64	CS06051002	4	螺栓 M5X10	OLT, SOCKET M5X10	
65	CS06051202	4	螺栓 M5X12	OLT, SOCKET M5X12	
66	CS08050602	2	螺钉 M5X6	SCREW, PAN M5X6	
67	CS79020310	1	剪线板	UTT CLOSE CAM B	
68	CS00800326	1	轴位螺钉 8	SHOULDER SCREW D8 H3. 2	
69	CS08060552	1	螺钉 M6X5	SCREW, PAN M6X5	
70	CS01511772	1	压脚组件(K)	WORK CLAMP CHECK HOLDER ASM(K)	
71	CS01511772	1	压脚板座	WORK CLAMP CHECK HOLDER	
72	CS01509761	2	压脚弹簧板	WORK CLAMP CHECK SPRING	
73	CS01510771	2	压脚弹簧定位销	WORK CLAMP CHECK SPRING SET PI	
74	CS01512761	1	压脚板座弹簧	WORK CLAMP CHECK HOLDER SPRING	
75	CS06060210	2	螺钉 SM3/32" -56	SCREW, SM3/32" -56	
76	CS01511771	1	压脚组件(S)	WORK CLAMP CHECK HOLDER ASM(S)	
77	CS01511771	1	压脚板座	PRESSER FOOT	
78	CS01509761	2	压脚弹簧板	WORK CLAMP CHECK SPRING	
79	CS01510771	2	压脚弹簧定位销	WORK CLAMP CHECK SPRING SET PI	
80	CS01512761	1	压脚板座弹簧	WORK CLAMP CHECK HOLDER SPRING	
81	CS06060210	2	螺钉 SM3/32" -56	SCREW, SM3/32" -56	
82	CS01552781	1	压脚板(S)	PRESSER(S)	
83	CS00790203	1	压脚螺钉	HINGE SCREW D7. 94 H2	
84	CS01508772	1	压脚板(K)	WORK CLAMP CHECK (2K)	
85	CS08050502	1	螺钉 M5X5	SET SCREW, SOCKET (FT) M5X5	
86	CS79004195	1	传感器定位板	SENSOR PLATE	
87	CS03070002	2	滚针轴承	NEEDLE BEARING	

F、针杆摇动部件/ Needle bar rocking components

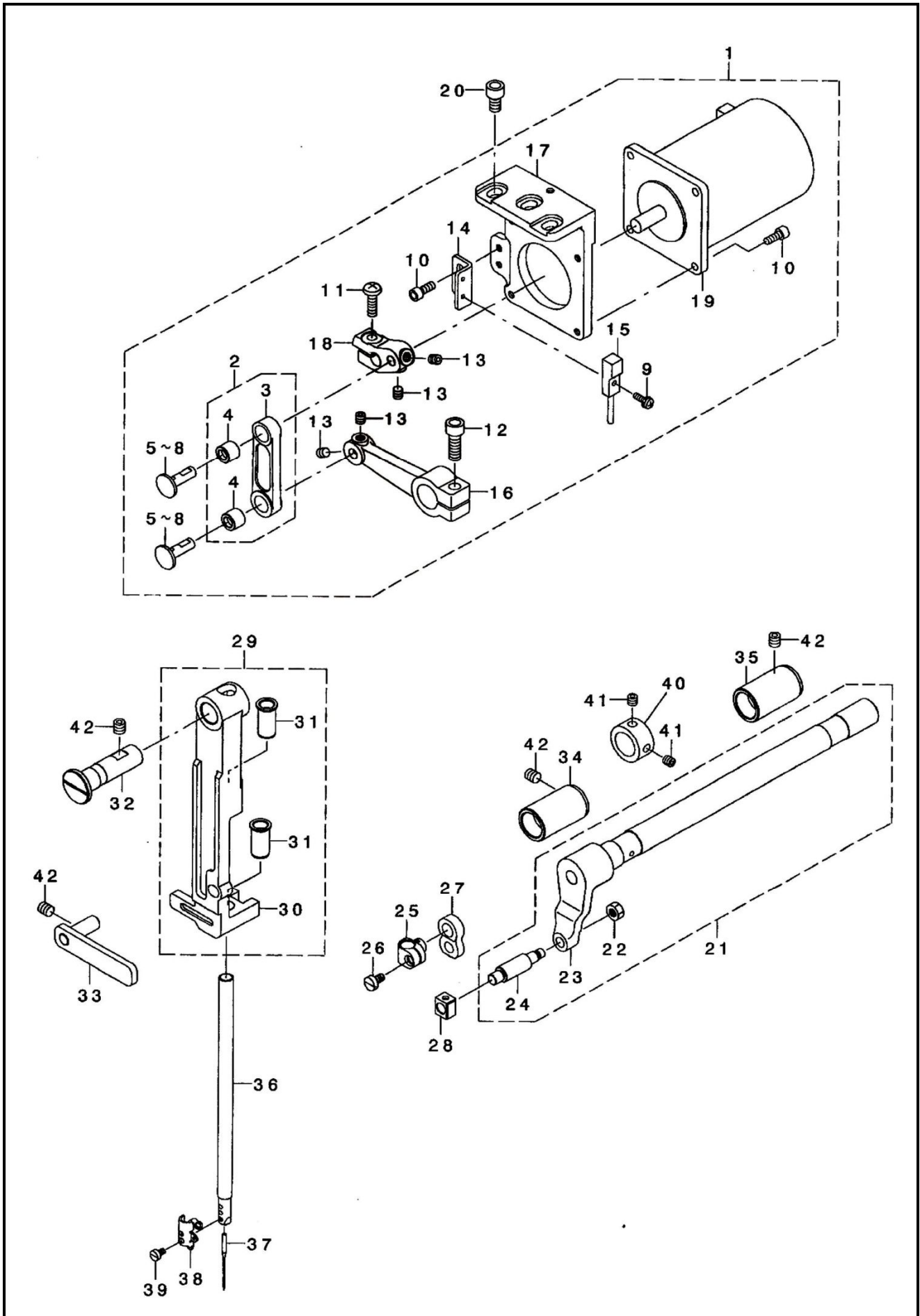

F、针杆摇动部件/ Needle bar rocking components

参照号	零部件序号	数量	零部件名称	NAME OF PARTS	RM
1	CS79004223	1	摆轴驱动组件	ZIGZAG DRIVE FULL ASSY	
2	CS79004378	1	摆轴连杆组件	ZIGZAG ROD ASM.	
3	CS79004379	1	摆轴连杆	ZIGZAG ROD	
4	CS79030405	2	轴套	SHAFT HOLDER LINK BUSH	
5	CS79044109	2	连接轴 A	JUNCTION SHAFT A	
6	CS79044208	2	连接轴 B	JUNCTION SHAFT B	
7	CS79044307	2	连接轴 C	JUNCTION SHAFT C	
8	CS79044802	2	连接轴 D	JUNCTION SHAFT D	
9	CS04031081	1	螺钉 M3X10	SCREW, PAN M3X10	
10	CS06041002	6	螺栓 M4X10	OLT, SOCKET M4X10	
11	CS04051655	1	螺栓 M5X16	OLT, SOCKET M4X16	
12	CS06061802	1	螺栓 M6X18	OLT, SOCKET M4X18	
13	CS08050502	4	螺钉 M5X5	SET SCREW, SOCKET (FT) M5X5	
14	CS79004376	1	传感器固定板	SENSOR PLATE	
15	CS79005377	1	针摆传感器	NEEDLE SWING SENSOR ASSY	
16	CS79004380	1	针杆摆动曲柄	ZIGZAG LEVER REAR	
17	CS79004375	1	电机安装板	MOTOR BASE	
18	CS79004377	1	电机连接曲柄	MOTOR LEVER	
19	CS79005371	1	针摆步进电机	NEEDLE SWING MOTOR ASS' Y	
20	CS06061002	3	螺栓 M6X10	OLT, SOCKET M6X10	
21	CS79004224	1	摆轴组件	ZIGZAG LEVER SHAFT ASM.	
22	CS06050001	1	螺母 M5	NUT M5	
23	CS79004373	1	摆轴	ZIGZAG LEVER SHAFT	
24	CS79004374	1	摆轴驱动轴	ZIGZAG STUD	
25	CS79004214	1	针杆连接杆	NEEDLE BAR CORNNESTION	
26	CS06040750	1	螺钉 M4X7	SCREW, PAN M4X7	
27	CS79004209	1	针杆连杆	NEEDLE BAR ROD	
28	CS01414232	1	针杆架滑块	SQUARE BLOCK	
29	CS79004222	1	针杆架组件	NEEDLE BAR FRAME ASSY	
30	CS79004212	1	针杆架	NEEDLE BAR FRAME	
31	CS79004213	2	针杆衬套	NEEDLE BAR METAL	
32	CS79004221	1	针杆架连接轴	WUPPORT SHAFT	
33	CS79004218	1	针杆架压板	FRAME SUPPORT PLATE ASM.	
34	CS79004216	1	摆轴前套	BUSHING	
35	CS79004217	1	摆轴后套	BUSHING REAR	
36	CS79004215	1	针杆	NEEDLE BAR	
37	CS5JOB1100	1	机针 DPX5 #11J	NEEDLE DPX5 #11J	
38	CS79006403	1	面线导向器	NEEDLE BAR BOBBIN THREAD GUIDE	
39	CS06030500	1	螺钉 M3X5	SCREW, PAN M3X5	
40	CS01501181	1	摆轴挡圈	THRUSR COLLAR D15 W11	
41	CS08050502	2	螺钉 M5X5	SET SCREW, SOCKET (FT) M5X5	
42	CS08060612	4	螺钉 M6X6	SET SCREW, SOCKET (FT) M6X6	

G、上剪线部件/ Needle thread trimmer components

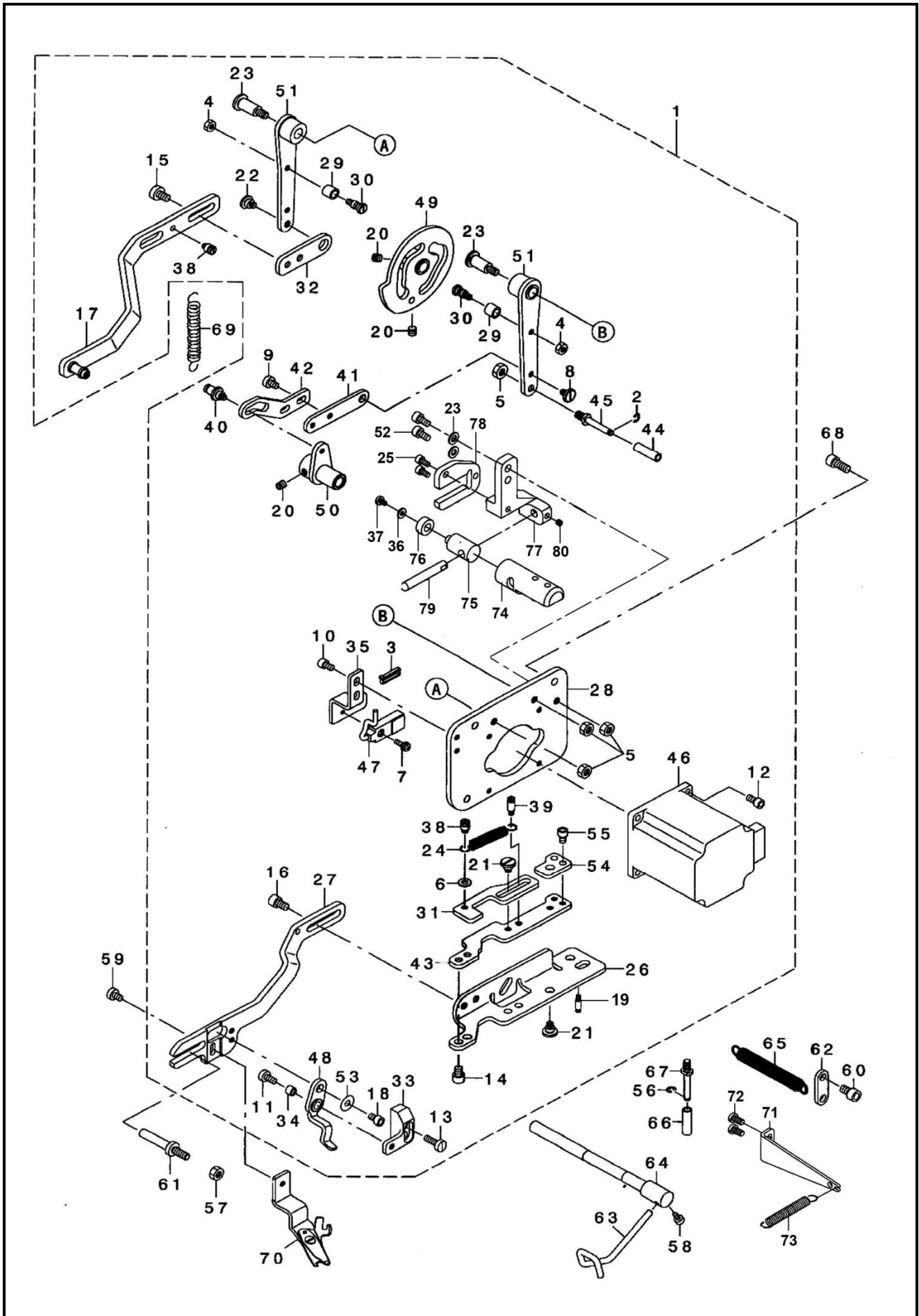

G、上剪线部件/ Needle thread trimmer components

参照号	零部件序号	数量	零部件名称	NAME OF PARTS	RM
1	CS79029904	1	剪面线组件	ASSY UTT MODULE	
2	CS00300000	1	挡圈 E3	RETAINING RING, E3	
3	CS09500B01	2	固定带	CABLE BAND	
4	CS06040000	4	螺母 M4	NUT M4	
5	CS06050001	1	螺母 M5	NUT M5	
6	CS00430801	1	垫圈 4. 3X9X0. 8	WAHER PLAIN 4. 3X9X0. 8	
7	CS04031081	1	螺钉 M3X10	SCREW, PAN M3X10	
8	CS00600266	1	螺钉 M4X8	SCREW, PAN M4X8	
9	CS06040600	2	螺钉 M4X6	SCREW, PAN M4X6	
10	CS06040602	2	螺栓 M4X6	OLT, SOCKET M4X10	
11	CS06040860	1	螺钉 M4X8	OLT, SOCKET M4X16	
12	CS06040802	4	螺栓 M4X8	OLT, SOCKET M4X18	
13	CS06041200	2	螺钉 M4X12	OLT, SOCKET M4X12	
14	CS06050652	2	螺栓 M5X6	OLT, SOCKET M5X6	
15	CS06050800	2	螺钉 M5X8	SCREW, PAN M5X8	
16	CS06050802	2	螺栓 M5X8	OLT, SOCKET M5X8	
17	CS79004400	1	开剪连杆组件	ASSY UTT RELEASE ARM	
18	CS06040602	1	螺栓 M4X6	OLT, SOCKET M4X6	
19	CS08050412	1	缓线钩定位螺钉	UTT SUPPENSION SCREW	
20	CS08050502	4	螺钉 M5X5	SET SCREW, SOCKET (FT)M5X5	
21	CS00600326	3	剪线导向板调节螺钉	SHOULDER SCREW D6 H3. 2	
22	CS00800406	1	剪线连接板轴位螺钉 M5	SHOULDER SCREW D8 H4	
23	CS00801506	2	垫圈	PLAIN WASHER	
24	CS79072507	1	导向板弹簧	SPRING	
25	CS00800971	2	螺钉	SCREW	
26	CS79004235	1	剪线支架	UTT ARM A	
27	CS79004238	1	剪刀架	UTT ARM B	
28	CS79004293	1	剪线电机安装板	UTT BASE PLATE	
29	CS79004254	2	滚柱	UTT CAM ROLLER	
30	CS79004253	2	滚柱连接螺钉	UTT CAM ROLLER SHAFT	
31	CS79015702	1	剪刀进退导向板	UTT RATCH PLATE B	
32	CS79004294	1	剪线连接板	UTT RELEASE ARM A	
33	CS79004264	1	开剪驱动板安装座	UTT RELEASE LEVER BASE	
34	CS79004265	1	连接小滚子	UTT RELEASE LEVER SHAFT	
35	CS79004292	1	传感器安装板	UTT SENSOR BASE	
36	CS79004296	1	垫圈	PLAIN WASHER	
37	CS79004234	1	螺钉	SCREW	
38	CS79004248	2	螺钉 4	UTT SUPPENSION SCREW 4	
39	CS79004252	1	缓线钩定位螺钉 9	UTT SUPPENSION SCREW 9	
40	CS79004247	1	缓线连接销	UTT SUPPENSION SHOULDER SCREW	
41	CS79004244	1	缓线钩连接板	UTT TGREAD PULLING LINK A	
42	CS79004245	1	缓线钩驱动板	UTT TGREAD PULLING LINK B	
43	CS79004236	1	剪刀进退固定板	UTT X CAM	
44	CS79004297	1	滚柱	UTT Y DRIVE ROLLER	
45	CS79004298	1	滚轴	UTT Y DRIVE SHAFT	
46	CS79005374	1	剪面线步进电机	UT TRIM MOTOR ASS' Y	
47	CS79005380	1	剪线传感器	UT TRIM SENSOR ASS' Y	
48	CS79028634	1	开剪驱动板组件	ASSY UTT RELEASE LEVER B	
49	CS79004229	1	剪线凸轮组件	ASSY UTT CAM	
50	CS79004240	1	缓线钩连接曲柄组件	ASSY UTT THREAD PULLING ARM	
51	CS79004226	1	缓线钩导向曲柄组件	ASSY UTT CAM ARM	
52	CS79004232	2	螺栓 M5X12	OLT, SOCKET M5X12	
53	CS00421005	1	垫圈 4. 3X12X1	PLAIN WASHER 4. 3X12X1	
54	CS79015674	1	限位板	UTT RATCH STOPPER	
55	CS06040602	2	螺栓 M4X6	OLT, SOCKET M4X6	
56	CS03000000	1	挡圈 E3	RETAINING RING E3	
57	CS60500001	1	螺母 M5	NUT M5	
58	CS06040602	1	螺栓 M4X6	OLT, SOCKET M4X6	
59	CS06040600	1	螺钉 M4X6	SCREW, PAN M4X6	
60	CS06050802	1	螺栓 M5X8	OLT, SOCKET M5X8	

G、上剪线部件/ Needle thread trimmer components

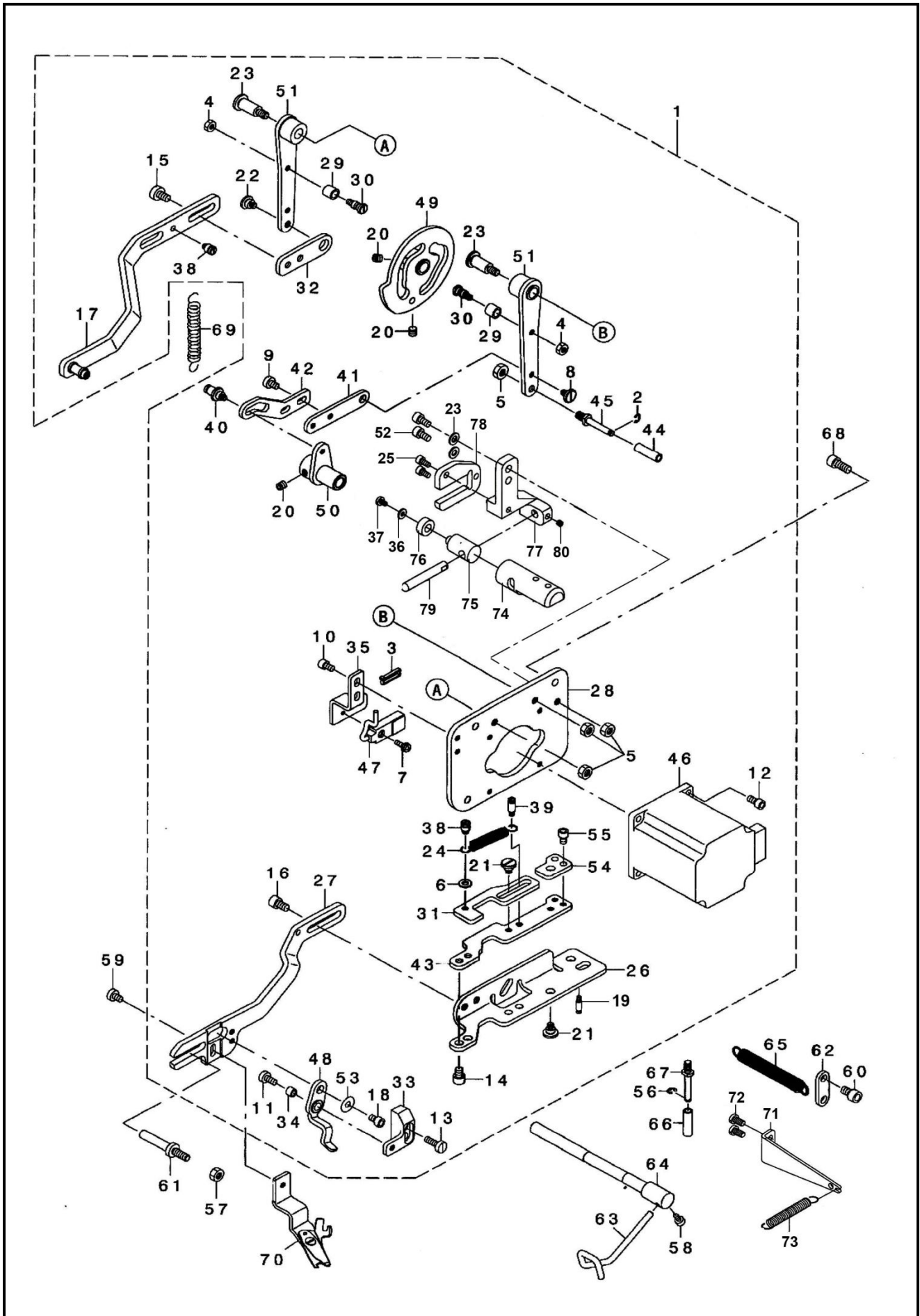

G、上剪线部件/ Needle thread trimmer components

参照号	零部件序号	数量	零部件名称	NAME OF PARTS	RM
61	CS79028636	1	压脚导向轴	UTT GUIDE SHAFT B	
62	CS79004249	1	连接板	UTT SUSPENSION PLATE	
63	CS79004243	1	缓线钩	UTT THREAD PULLING LEVER	
64	CS79004246	1	缓线钩轴	UTT THREAD PULLING SHAFT	
65	CS79004250	1	剪线弹簧	UTT TRIMMER CLOSE SPRING	
66	CS79004297	1	滚柱	UTT Y-DRIVE ROLLER	
67	CS79004298	1	剪刀控制轴	UTT Y-DRIVE SHAFT	
68	CS06051202	3	螺栓 M5X12	OLT, SOCKET M5X12	
69	CS16013000	1	缓线钩复位弹簧	BUTTON SUPPORT LEVER SPRING	
70	CS79004255	1	上剪线刀组件	ASSY UTT TRIMMER	
71	CS79002101	1	拉簧支架	UTT ARM	
72	CS7900210	2	螺钉	SCREW	
73	CS7900210	1	拉簧	SPRING	
74	CS79004234	1	剪线支架连接轴	UTT SUPPORT SHAFT	
75	CS7900210	1	连接柱	UTT SUPPENSION SHOULDER SCREW	
76	CS7900210	1	滚柱	UTT CAM ROLLER	
77	CS7900210	1	支架	UTT ARM	
78	CS7900210	1	导向板	UTT RATCH PLATE	
79	CS7900210	1	轴销	UTT SUPPORT SHAFT	
80	CS08040402	1	螺钉 M4X4	SET SCREW, SOCKET (FT) M4X4	

H、下剪线部件/ Bobbin thread trimmer components

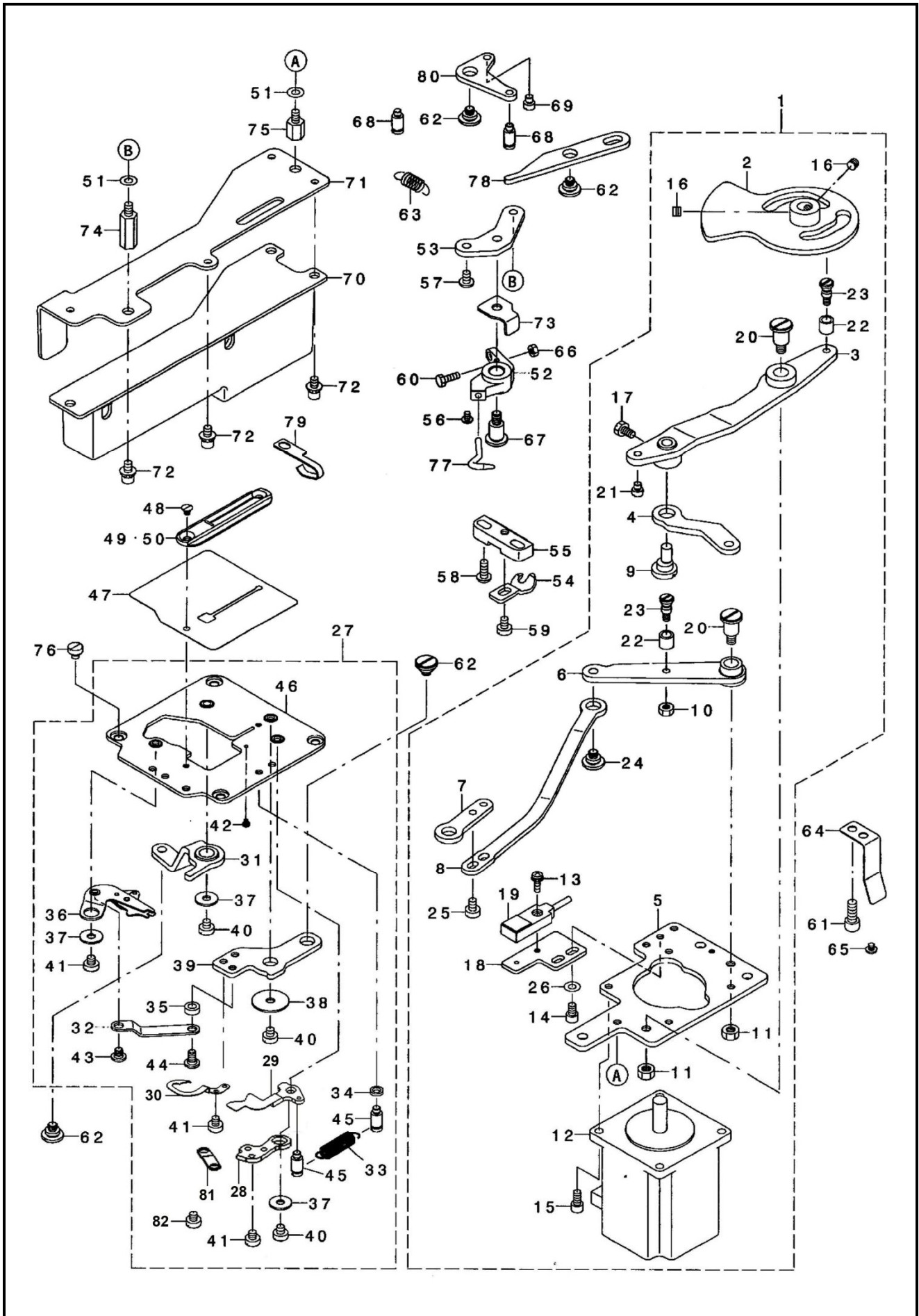

H、下剪线部件/ Bobbin thread trimmer components

参照号	零部件序号	数量	零部件名称	NAME OF PARTS	RM
1	CS79004330	1	剪底线组件	BTT DRIVE UNIT	
2	CS79004332	1	剪底线凸轮组件	ASSY BTT DRIVE CAM	
3	CS79004336	1	剪底线连杆组件	ASSY BTT DRIVE LEVER	
4	CS79004329	1	剪底线连杆	BTT DRIVE LINK	
5	CS79004331	1	底线电机安装板	BTT DRIVE UNIT BASE	
6	CS79004340	1	剪底线导向曲柄组件	ASSY BTT RELEASE LEVER	
7	CS79004343	1	剪刀调节板	BTT RELEASE LINK F	
8	CS79004344	1	剪底线导向曲柄连杆	BTT RELEASE LINK R	
9	CS79037408	1	偏心轴销	LINK ROD	
10	CS06040001	1	螺母 M4	NUT M4	
11	CS06050001	2	螺母 M5	NUT M5	
12	CS79005375	1	剪底线步进电机	LT TRIM MOTOR ASS' Y	
13	CS04031081	1	螺钉 M3X10	SCREW, PAN M3X10	
14	CS06040602	2	螺栓 M4X6	OLT, SOCKET M4X6	
15	CS06040802	4	螺栓 M4X8	OLT, SOCKET M4X8	
16	CS08050412	2	螺栓 M5X4	OLT, SOCKET M5X4	
17	CS09040700	1	螺栓 M4X7	OLT, SOCKET M4X7	
18	CS79004335	1	传感器安装板	SENSOR FITTING PLATE BT	
19	CS79005381	1	传感器	LT TRIM SENSOR ASS' Y	
20	CS00801006	2	轴位螺钉	SHOULDER SCREW D8 H10	
21	CS79004299	1	止动销	STOPPER PIN	
22	CS79004254	2	滚柱	UTTCAM ROLLER	
23	CS79004253	2	滚子连接销	UTTCAM ROLLER SHAFT	
24	CS00800296	1	轴位螺钉	SHOULDER SCREW D8 H2.9	
25	CS06040600	2	螺钉 M4X6	SCREW, PAN M4X6	
26	CS00430801	2	垫圈 4. 3X9X0. 8	WAOHER PLAIN 4. 3X9X0. 8	
27	CS79021998	1	针板组件	THROAT PLATE BASE UNIT	
28	CS79022323	1	剪线器压板	BT CLAMP B	
29	CS79004309	1	固定板	BT CLAMP LEVER	
30	CS79022322	1	底线导线器	BT PULLER B	
31	CS79004321	1	剪线控制板组件	ASSY BT RELEASE ARM	
32	CS79004308	1	传动连接杆	BT TRIMMER LINK	
33	CS79029613	1	弹簧	CLAMP SPRING	
34	CS01623180	1	垫圈	WASHER	
35	CS03012141	1	垫圈	WASHER	
36	CS79004311	1	下剪线刀组件	BT TRIMMER	
37	CS00431005	3	垫圈 4. 3X12X1	WAOHER PLAIN 4. 3X12X1	
38	CS00451016	1	垫圈 4. 5X20X1	WAOHER PLAIN 4. 5X20X1	
39	CS79004306	1	剪底线传动板	BTT LEVER	
40	CS06040450	3	螺钉 M4X4	SCREW, PAN M4X4	
41	CS06040450	5	螺钉 M4X4	SCREW, PAN M4X4	
42	CS00250101	1	轴位螺钉	SHOULDER SCREW	
43	CS00500166	1	轴位螺钉	SHOULDER SCREW D5 H1. 6	
44	CS00500167	1	轴位螺钉	SHOULDER SCREW D5 H1. 6	
45	CS79004327	2	挂簧螺钉	SHSPENSION SCREW	
46	CS79004301	1	剪线组件安装板	ASSY THROAT PLATE BASE	
47	CS79004324	1	防油板	OIL SHIELD	
48	CS01030400	2	螺钉 M3X4	SCREW, PAN M4X4	
49	CS79027553	1	针板(S)	THROAT PLATE (1790S5)	
50	CS79027554	1	针板(K)	THROAT PLATE (1790K5)	
51	CS00430800	2	平垫圈 M4	WAOHER PLAIN M4	
52	CS79004345	1	下挡线器座	PICKER BASE	
53	CS79004347	1	下挡线器连接板	PICDER BASE FITTNG PLATE	
54	CS79027102	1	旋梭定位钩	STOPPER A	
55	CS79029306	1	定位钩安装板	BOBBIN CASE POSITIONING PLATEE	
56	CS04030455	1	螺钉 M3X4	SCREW, PAN M3X4	
57	CS06040602	1	螺钉 M4X6	SCREW, PAN M4X6	
58	CS04041050	2	螺钉 M4X10	SCREW, PAN M4X10	
59	CS06040600	1	螺钉 M4X6	SCREW, PAN M4X6	
60	CS06041200	1	螺栓 M4X12	OLT, SOCKET M4X12	

H、下剪线部件/ Bobbin thread trimmer components

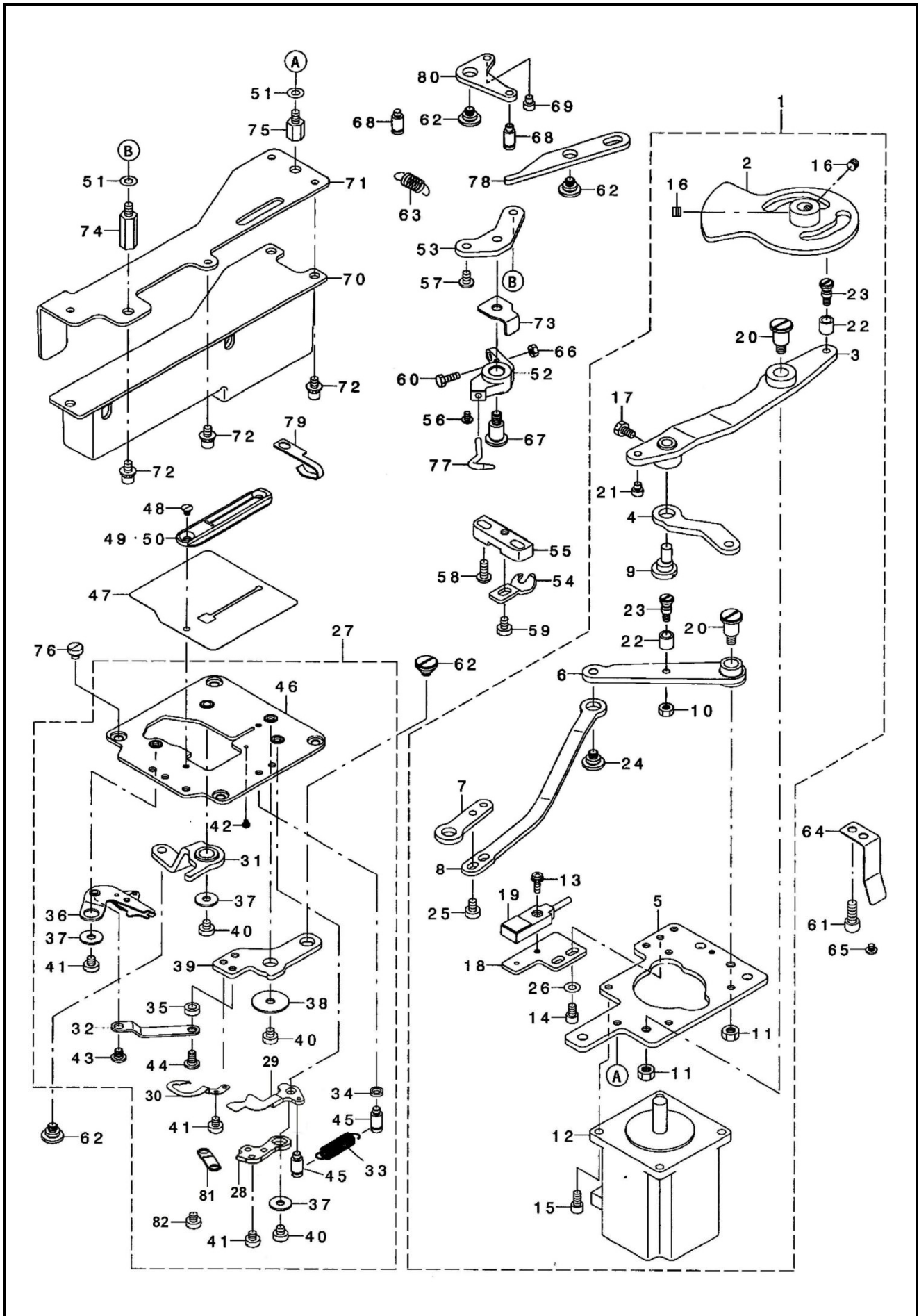

H、下剪线部件/ Bobbin thread trimmer components

参照号	零部件序号	数量	零部件名称	NAME OF PARTS	RM
61	CS06050802	3	螺栓 M5X8	OLT, SOCKET M5X8	
62	CS00800296	4	轴位螺钉	SHOULDER SCREW D8 H2.9	
63	CS79011327	1	弹簧	PICKER SPRING	
64	CS79016801	1	安全开关板	SAFETY SWITCH PRESSING PLATE	
65	CS05030355	1	螺钉 M3X3	SCREW, PAN M3X3	
66	CS06040001	1	螺母 M4	NUT M4	
67	CS00801006	1	轴位螺钉	SHOULDER SCREW D8 H10	
68	CS79004327	2	挂簧螺钉	SHSPENSION SCREW	
69	CS79004299	1	止动销	STOPPER PIN	
70	CS79004164	1	油盒组件	OIL TANK ASM.	
71	CS79004163	1	油盒安装板	OIL TANK PLATE	
72	CS06040892	6	螺钉(带垫圈)M4X8	SCREW, PAN(S/P WASHER)M4X8	
73	CS79004328	1	止动板	PICKER BASE STOPPER	
74	CS00033900	1	螺钉	PARTS	
75	CS00033900	1	螺钉	STUD	
76	CS06040450	4	螺钉 M4X4	SCREW, PAN M4X4	
77	CS79004346	1	下挡线器	PICKER	
78	CS79004348	1	下挡线传动杆	PICKER ACTUATING LEVER	
79	CS79030409	1	润滑油管固定片	LUBRICATING OIL WICK STOPPER	
80	CS79004349	1	下挡线传动板	PICKER ACTUATING L LINK	
81	CS79002501	1	连接板	BT CLAMP LEVER	
82	CS79002502	1	轴位螺钉	SHOULDER SCREW	

J、切刀部件/ Cloth cutting knife components

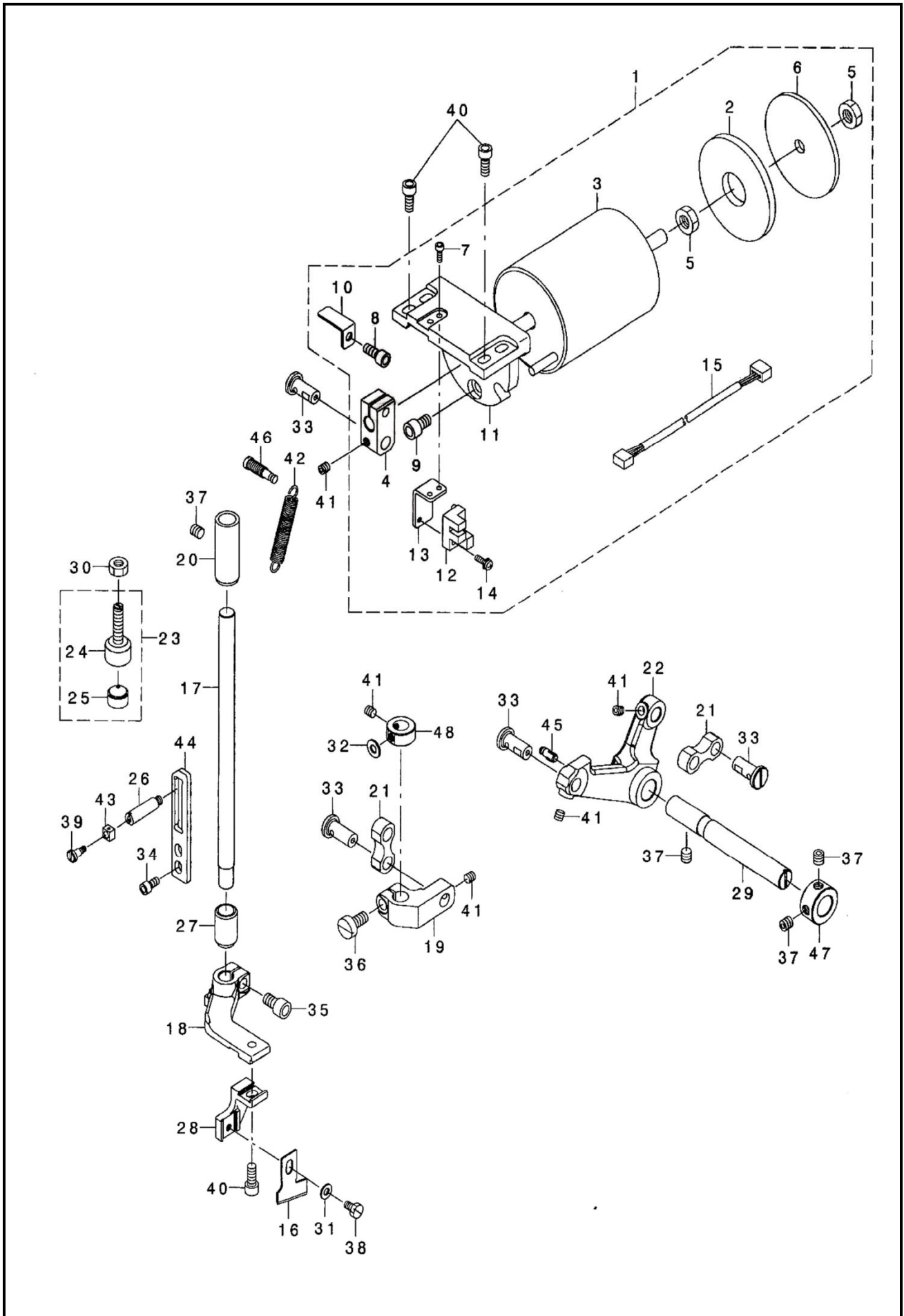

J、切刀部件/ Cloth cutting knife components

参照号	零部件序号	数量	零部件名称	NAME OF PARTS	RM
1	CS79004381	1	切线驱动组件	KNIFE SOL ASM.	
2	CS79004384	1	橡胶缓冲垫	CUSION	
3	CS79004382	1	切刀电磁铁	SOLENOID	
4	CS79009788	1	刀杆座	KNIFE HOLDER	
5	CS06080003	2	螺母 M8	NUT M8	
6	CS79004383	1	后置板	PLATE A	
7	CS06030802	2	螺栓 M3X8	OLT, SOCKET M3X8	
8	CS06051202	1	螺栓 M5X12	OLT, SOCKET M5X12	
9	CS06061002	3	螺栓 M6X10	OLT, SOCKET M6X10	
10	CS79004387	1	传感器安装板	SENSOR SLIT PLATE	
11	CS79004385	1	电磁铁安装座	SOLENOID BASE	
12	CS00005700	1	传感器	PHOTO SENSOR	
13	CS79004386	1	传感器安装板	SENSOR PLATE	
14	CS04031091	1	螺钉(带垫圈)M3X10	SCREW, PAN(S/P WASHER)M3X10	
15	CS79005382	1	电线	CUTTER SENSOR JOINT CLRD	
16	CS02702047	1	刀片 1/2"	KNIFE 1/2"	
17	CS79004394	1	切刀轴	KNIFE BAR	
18	CS79004396	1	切刀杆座	KNIFE BAR BASE	
19	CS79004397	1	切刀杆支架	KNIFE BAR BRACKET	
20	CS79004398	1	切刀杆上衬套	KNIFE BAR BUSH	
21	CS79046508	2	切刀驱动连杆	KNIFE BAR CONNECTING LINK	
22	CS79004390	1	驱动曲柄	KNIFE BAR DRIVING LEVER	
23	CS79004219	1	限位螺钉组件	KNIFE BAR DRIVING STOPPER ASM.	
24	CS79004391	1	切刀限位螺钉	KNIFE BAR DRIVING STOP SCREW	
25	CS79050807	1	缓冲垫	KNIFE DRIVING LEVER STOPPER	
26	CS79004210	1	支撑轴	KNIFE BAR SUPPORT SHAFT	
27	CS79040276	1	切刀杆下衬套	KNIFE BAR LOWER BUSHING	
28	CS79004393	1	切刀安装座	KNIFE FITTING BASE	
29	CS79004395	1	驱动轴	KNIFE LEVER SHAFT	
30	CS06060002	1	螺母 M6	NUT M6	
31	CS00430801	1	垫圈 4. 3X9X0. 8	WAOHER PLAIN 4. 3X9X0. 8	
32	CS00501016	1	垫圈 5X10. 5X1	WAOHER PLAIN 5XX10. 5X1	
33	CS79004392	4	曲柄轴	BELL CRANK SHAFT	
34	CS06040802	2	螺栓 M4X8	OLT, SOCKET M4X8	
35	CS06061202	1	螺栓 M6X12	OLT, SOCKET M6X12	
36	CS06061200	1	螺钉 M6X12	SCREW, PAN M6X12	
37	CS08060612	4	螺钉 M6X6	SET SCREW, SOCKET (FT)M6X6	
38	CS09040700	1	螺钉 M4X6	SCREW, PAN M4X6	
39	CS00400506	1	切刀导向轴位螺钉	SHOULDER SCREW D4 H5	
40	CS06051202	5	螺栓 M5X12	OLT, SOCKET M5X12	
41	CS08050502	5	螺钉 M5X5	SET SCREW, SOCKET (FT)M5X5	
42	CS79004389	1	弹簧	SPRING	
43	CS79006315	1	滑块	SQUARE BLOCK	
44	CS79004211	1	支撑导向板	SUPPORT GUIDE	
45	CS79038802	1	挂簧销	SUSPENSION SCREW	
46	CS79004179	1	挂簧螺钉	SUSPENSION SCREW	
47	CS01201171	1	驱动轴挡圈	SHOULDER SCREW D12 H11	
48	CS79006313	1	切刀杆支架挡圈	COLLAR	

K、操作面板、电控开关部件/ Operation box & position pedal components

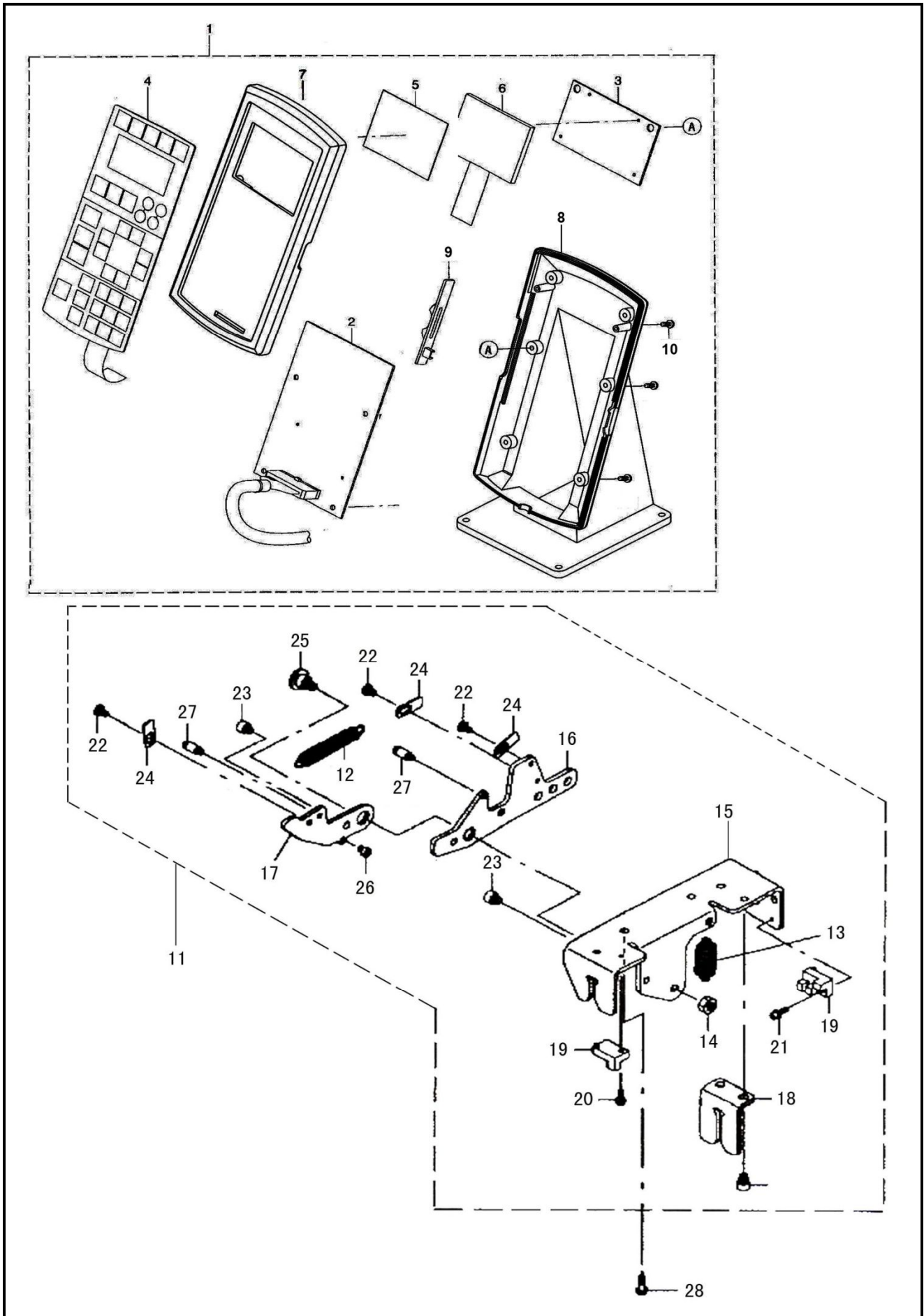

K、操作面板、电控开关部件/ Operation box & position pedal components

参照号	零部件序号	数量	零部件名称	NAME OF PARTS	RM
1	CS79003465	1	操作盘组件	OPERATION PANEL ASS' Y	
2	CS79003434	1	操作电路板组件	PANEL1 PCB A ASS' Y	
3	CS79003441	1	电路板组件	PANEL2 PCB ASS' Y	
4	CS79003460	1	按键板	PANEL SHEET	
5	CS79003462	1	显示屏保护板	LCD SHEET	
6	CS00074700	1	显示屏组件	LCD MODULE	
7	CS79003464	1	操作盘盖	OPERATION BOX UPPER CASE	
8	CS01031580	1	操作盘座	OPERATION BOX LOWER CASE	
9	CS01032580	1	开关拨盘	VOLUME TONGUE	
10	CS03452001	6	木螺钉 ST3X12	WOOD SCREW, FLAT ST3X12	
11	CS79003491	1	电控开关组件	ASSY 4 POSITION PEDAL	
12	CS79031906	1	弹簧	SPRING	
13	CS02583210	1	弹簧	SPRING	
14	CS06060001	1	螺母 M6	NUT M6	
15	CS79004360	1	电控开关固定架	PEDAL FRAME	
16	CS79004361	1	电控开关 A	PEDAL FRAME A	
17	CS79004362	1	电控开关 B	PEDAL FRAME B	
18	CS79004363	1	传感器固定架	PEDAL FRAME GUIDE	
19	CS00005700	2	传感器	PHOTO SENSOR	
20	CS04031091	1	螺钉(带垫圈)M3X10	SCREW, PAN(S/P WASHER) M3X10	
21	CS06031042	1	螺钉(带垫圈)M3X10	SCREW, PAN(S/P WASHER) M3X10	
22	CS05040655	3	螺钉(带垫圈)M4X6	SCREW, PAN(S/P WASHER) M4X6	
23	CS06050652	4	螺栓 M5X6	OLT, SOCKET M5X6	
24	CS79004364	3	传感器检测板	SHNSOR DETECTING PLATE	
25	CS01000646	1	轴位螺钉	SHOULDER SCREW D10 H6. 4	
26	CS79004299	1	止动销	STOPPER PIN	
27	CS79004327	2	挂簧螺钉	SUSPENSION SCREW	
28	CS03452001	2	木螺钉 M4. 5X20	WOOD SCREW, FLAT M4. 5X20	

L、控制箱部件/ Control box components

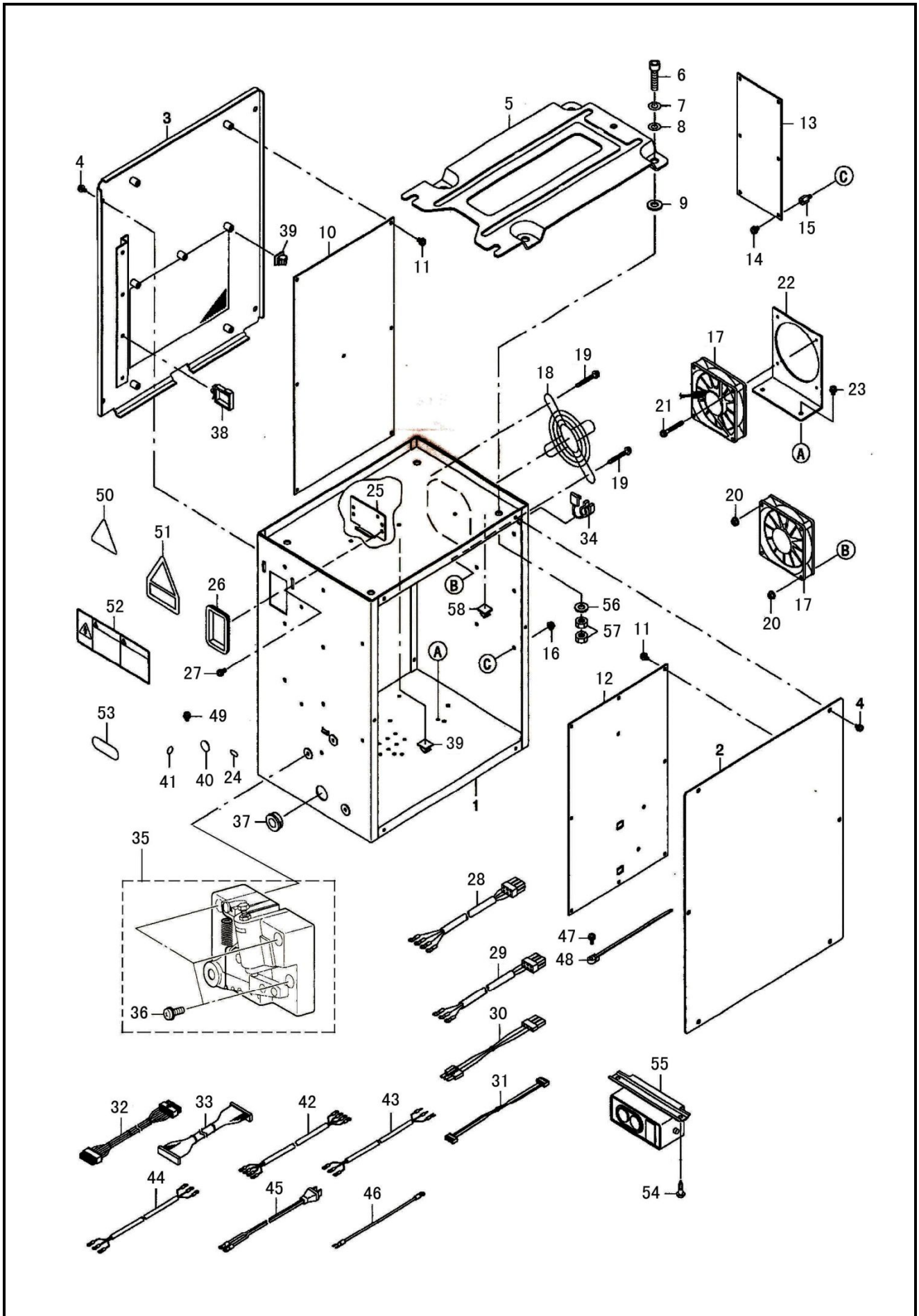

L、控制箱部件/ Control box components

参照号	零部件序号	数量	零部件名称	NAME OF PARTS	RM
1	CS79003451	1	电控箱	CONTROL BOX	
2	CS79003452	1	前盖板	CONTROL BOX FRONT COVER	
3	CS79003453	1	后盖板	CONTROL BOX REAR XOVER	
4	CS04040891	10	螺钉(带垫圈)M4X8	SCREW, PAN(S/P WASHER)M4X8	
5	CS03801476	1	电控箱安装板	CONTROL BOX FITTING PLATE	
6	CS06083002	4	螺栓 M8X30	OLT, SOCKET M8X30	
7	CS00820002	4	弹垫圈 M8	SPRING WASHER, M8	
8	CS00841601	4	平垫圈 8. 4X17. 4X1. 6	WAOHER PLAIN 8. 4X17. 4X1. 6	
9	CS04206461	4	垫圈	WAOHER	
10	CS79003412	1	电源板	MAIN PCB A ASS' Y	
11	CS04040881	17	螺钉(带垫圈)M4X8	SCREW, PAN(S/P WASHER)M4X8	
12	CS79000029	1	电路板	SDC PCB A ASS' Y	
13	CS79000056	1	主板	FLT-T PCB A ASS' Y	
14	CS04040881	6	螺钉(带垫圈)M4X8	SCREW, PAN(S/P WASHER)M4X8	
15	CS00033900	6	螺柱	STUD	
16	CS03040520	6	法兰螺母 M4	NUT M4	
17	CS79005401	2	风扇组件	FAN MOTOR ASS' Y	
18	CS00004800	1	风扇滤网	FINGER GUIDE	
19	CS04043591	4	螺钉(带垫圈)M4X35	SCREW, PAN(S/P WASHER)M4X35	
20	CS03040520	4	法兰螺母 M4	NUT M4	
21	CS04033091	4	螺钉 M3X30	SCREW, PAN M3X30	
22	CS79005404	1	风扇安装板	FAN MOTOR BRACKET	
23	CS04040891	2	螺钉 M4X8	SCREW, PAN M4X8	
24	CS02001000	1	PE 标签	PE MARK LABEL	
25	CS00040700	1	电线护圈	BUSH	
26	CS79045009	1	电线挡板	BORD FITTING PLATE	
27	CS04041091	2	螺钉 M4X10	SCREW, PAN M4X10	
28	CS79005391	1	电缆线	POWER CORD 3P ASS' Y	
29	CS79005388	1	220V 电源线	POWER CORD 1P 220V ASS' Y	
30	CS79005393	1	电缆线组件	FLT-SDC CORD P ASS' Y	
31	CS79005394	1	电缆线组件	FLT-SDC CORD S ASS' Y	
32	CS79005395	1	电缆线组件	SDC-MAIN CORD P ASS' Y	
33	CS79005396	1	电缆线组件	SDC-MAIN CORD S ASS' Y	
34	CS00041000	1	电线衬套	BUSHING	
35	CS79003484	1	踏板组件	PEDAL SENSOR ASM.	
36	CS04041681	3	螺钉 M4X16	SCREW, PAN M4X16	
37	CS00188000	1	电线护套	BUSH	
38	CS00051100	2	电线卡	WIRE SADDLE	
39	CS09607603	2	电线夹	STICKER (SMALL)	
40	CS79003458	1	标签	NASJ SEAK	
41	CS09567319	1	标签	EARTH MARK	
42	CS09017580	1	电缆线	POWER CABLE ASM.	
43	CS79005390	1	电缆线	POWER CABLE JE ASS' Y	
44	CS09024580	1	电缆线 100V	POWER CABLE ASM. , 100V	
45	CS09035580	1	电缆线	POWER WOURCE COUD ASM.	
46	CS09019580	1	接地线	EARTH CABLE ASM.	
47	CS04041081	1	螺钉 M4X10	SCREW, PAN M4X10	
48	CS00015100	1	扎带	CABLE PARTS	
49	CS04040891	1	螺钉(带垫圈)M4X8	SCREW, PAN(S/P WASHER)M4X8	
50	CS03001000	1	电压警告标签	VOLTAGE WARNING LABEL (25)	
51	CS03004006	1	电压提示标签	VOLTAGE CAUTION LABEL	
52	CS03001004	1	操作注意标签	DENGER LABEL 3 (LARGE)	
53	CS03200000	1	220V 标签	VOLTAGE INDICATION SEAL	
54	CS03512001	2	木螺钉 M5X20	WOOD SCREW M5X20	
55	CS00042500	1	开关组件	SWITCH	
56	CS00841601	4	平垫圈 8. 4X17. 4X1. 6	WAOHER PLAIN 8. 4X17. 4X1. 6	
57	CS06080001	8	螺母 M8X1. 25	NUT M8X1. 25	
58	CS09607603	1	电线夹	STICKER (SMALL)	

M、附件/ Accessories

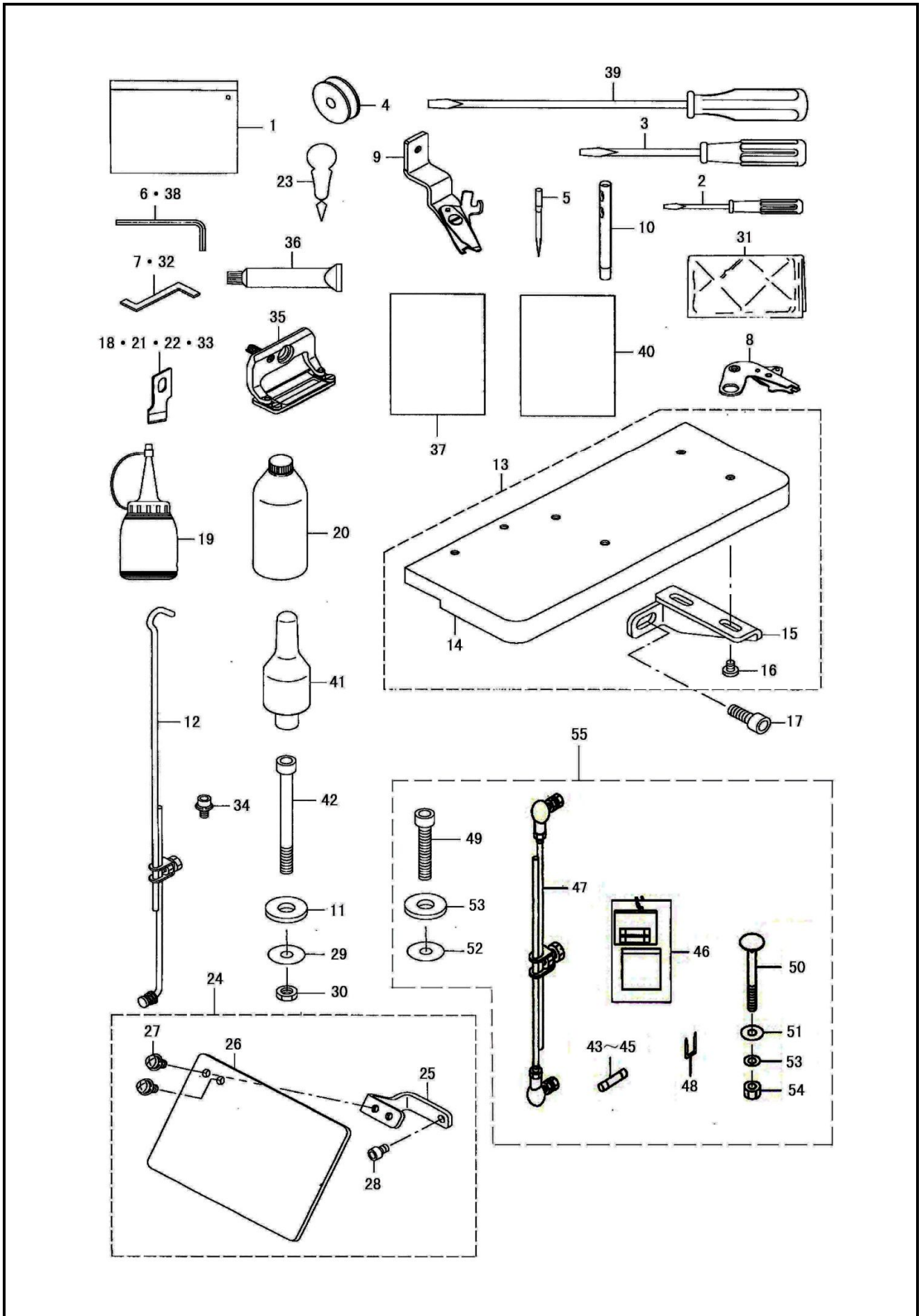

M、附件/ Accessories

参照号	零部件序号	数量	零部件名称	NAME OF PARTS	RM
1	CS79032800	1	机头罩	ACCESSORIE BAG	
2	CS79033204	1	一字螺丝刀(小)	SCREW DRIVER, SMALL	
3	CS79033105	1	一字螺丝刀(中)	SCREW DRIVER, MIDDLE	
4	CS79009148	1	梭芯	BOBBIN	
5	CS5JOB1102	1	机针 #12	NEEDLE DPX5 #12	
6	CS01066000	1	内六角扳手	HEXAGONAL WRENCH, 2	
7	CS79082107	1	定时调节钩	HOOK TIMING GAUGE, K	
8	CS79004311	1	夹线装置	BT TRIMMER	
9	CS79004255	1	剪线装置	ASSY UTT TRIMMER	
10	CS79002504	1	过线轴	THREAD GUIDE BAR	
11	CS06056555	4	垫圈	RUBBER CUSHION(B)	
12	CS79004851	1	拉杆组件	CONNECTING ROD COMPL.	
13	CS79008890	1	辅助桌板组件	AUXILIARY TABLE ASM.	
14	CS79008889	1	辅助桌板	AUXILIARY TABLE	
15	CS79085803	2	托架	INSTALLING PLATE	
16	CS07110570	4	螺钉 SM11/64" -40	SCREW, PAN SM11/64" -40	
17	CS06061002	2	螺栓 M6X10	OLT, SOCKET M4X10	
18	CS02702047	1	切刀 1"	KNIFE 1"	
19	CS01067000	1	油壶组件	OILER ASSY	
20	CSRX1600C0	1	油罐组件	OIL TANK ASSY	
21	CS2702047M	1	切刀 5/8"	KNIFE 5/8"	
22	CS2702047L	1	切刀 1/2"	KNIFE 1/2"	
23	CS09107761	1	穿线钩	THREAD PASSING INSTRUMENT	
24	CS79052047	1	护眼板组件	ASSY SAFETY PLATE B	
25	CS79049424	1	护眼板托架	SAFETY PLATE BESE	
26	CS03120372	1	护眼板	SAFETY PLATE	
27	CS04040891	2	螺钉(带垫圈)M4X8	SCREW, PAN(S/P WASHER) M4X8	
28	CS06040602	1	螺栓 M4X6	OLT, SOCKET M4X6	
29	CS00612056	4	垫圈 6. 1X18. 5X2	WAOHER PLAIN 6. 1X18. 5X2	
30	CS06060001	8	螺母 M6	NUT M6	
31	CS79034005	1	附属品塑料袋	ACCESSORY BAG	
32	CS79043402	1	定时调节钩	TIMING GAUGE, DMESTIC USE.	
33	CS2702047K	1	切刀 3/8"	KNIFE 3/8"	
34	CS06040892	1	螺栓	BOLT	
35	CS01552782	1	压脚组件	PRESSER FOOT 2 ASM.	
36	CS79006323	1	润滑脂组件	GREASE UNIT	
37	CS06001002	1	零件手册	PARTS BOOK	
38	CS02906000	1	内六角扳手	HEXAGONAL WRENCH, 3	
39	CS79033006	1	一字螺丝刀(大)	SCREW DRIVER, LARGE	
40	CS79080403	1	说明书	INSTRUCTION MANUAL	
41	CS79001208	1	机头撑杆	HEAD REST	
42	CS06067052	4	螺栓 M6X70	HEXAGON BOLT	
43	CS00013031	1	保险丝 250V-15A	G FUSE S 15A	
44	CS00030002	1	保险丝 250V-2A	G FUSE S 2A	
45	CS00013050	1	保险丝 250V-5A	G FUSE S 5A	
46	CS03004511	1	电压指示牌	VOLTAGE INDICATION SARD, A	
47	CS79058458	1	脚踏拉杆	CONNECTING ROD ASM. B	
48	CS11532000	3	线卡	STAPLE	
49	CSHJ100003	1	螺栓 M8X40	HEXAGON BOLT	
50	CS06084002	2	螺栓 M8X60	OLT, SOCKET M8X40	
51	CS00852086	3	平垫圈 M8	ASHER, PLAIN M8	
52	CS00852086	1	垫圈	ASHER	
53	CS00820002	3	弹簧垫圈 M8	WASHER, SPRING M8	
54	CS06080002	2	螺母 M8	NUT M8	
55	CS79005385	1	连接组件	ACCESSORIE PARTS A ASM.	

N53、线架装置部件/ Thread stand components

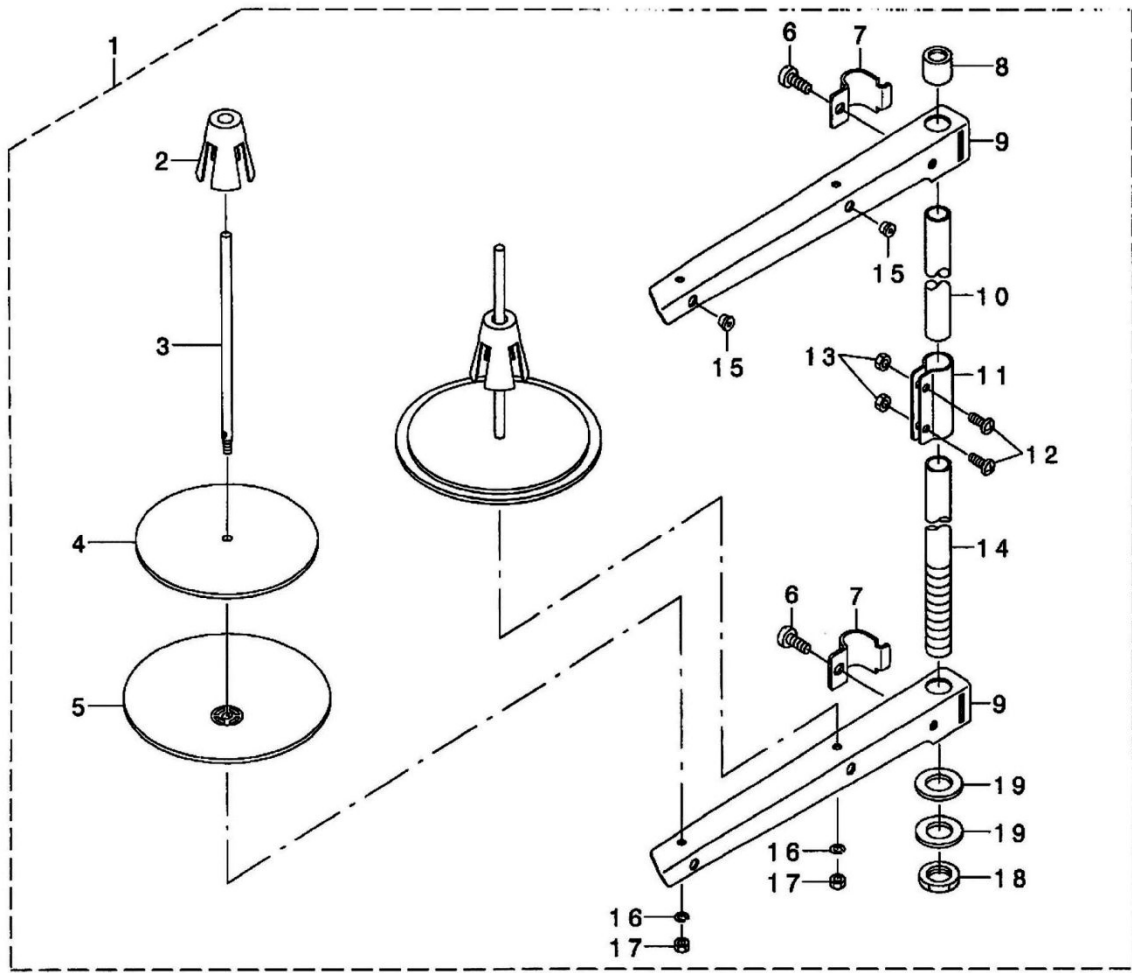

N、线架装置部件/ Thread stand components

参照号	零部件序号	数量	零部件名称	NAME OF PARTS	RM
1	CS79030358	1	线架组件	COTTON STAND ASSY	
2	CS79031109	2	线轴缓冲架	SPOOL CUSHION	
3	CS79031000	2	线轴	SPOOL SHAFT	
4	CS79030903	2	线盘软垫	SPOOL MAT	
5	CS79030804	2	垫圈	SPOOL STAND BASE	
6	CS06061610	2	螺钉 M6X16	SCREW, PAN M6X16	
7	CS79030705	2	卡扣	THREAD GUIDE ARM JOINT	
8	CS79031406	1	线架支撑管套	COLUMN CAP	
9	CS79030507	2	过线架	THREAD HANGER	
10	CS79030408	1	线架支撑管	SPOOL REST ROD, UPPER	
11	CS79031307	1	撑管夹	SPOOL REST ROD JOINT	
12	CS04051405	2	螺钉 M5X14	SCREW, PAN M5X14	
13	CS06050001	2	螺母 M5	NUT M5	
14	CS79030309	1	线架撑管	COLUMN PIPE	
15	CS79031208	2	过线架上过线管	THREAD BUSH	
16	CS00510002	2	垫圈 5. 1X9. 2X1. 3	WAOHER PLAIN 5. 1X9. 2X1. 3	
17	CS06050001	2	螺母 M5	NUT M5	
18	CS06060511	1	螺母 M16X1. 5	NUT M16X1. 5	
19	CS01702600	2	垫圈 17X30X2. 6	WAOHER PLAIN 6. 1X18. 5X2	

P、特殊类型部件/ Special specifications components

LARGE SIZE TUPE (FOR 70MM, 120MM)
锁眼长度70MM, 120MM

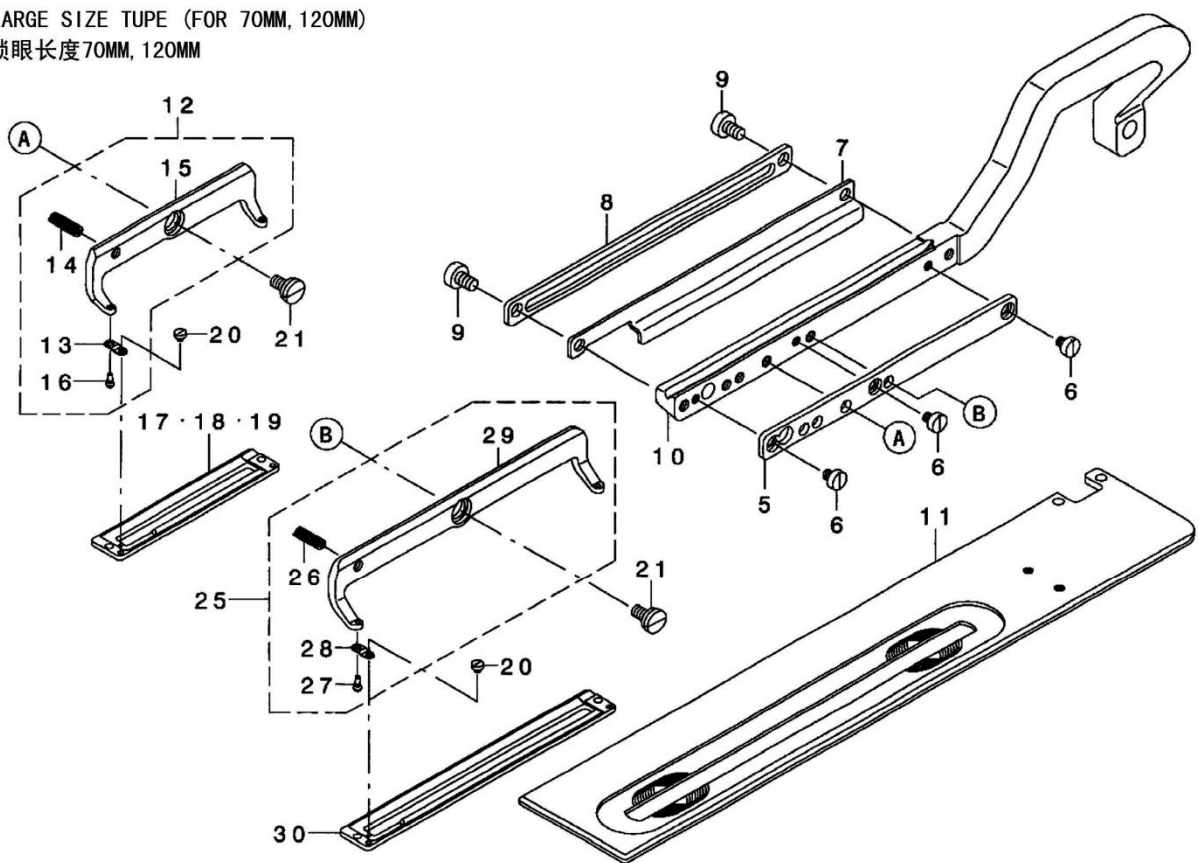

SWING WIDTH 10MM TUPE
针幅10MM

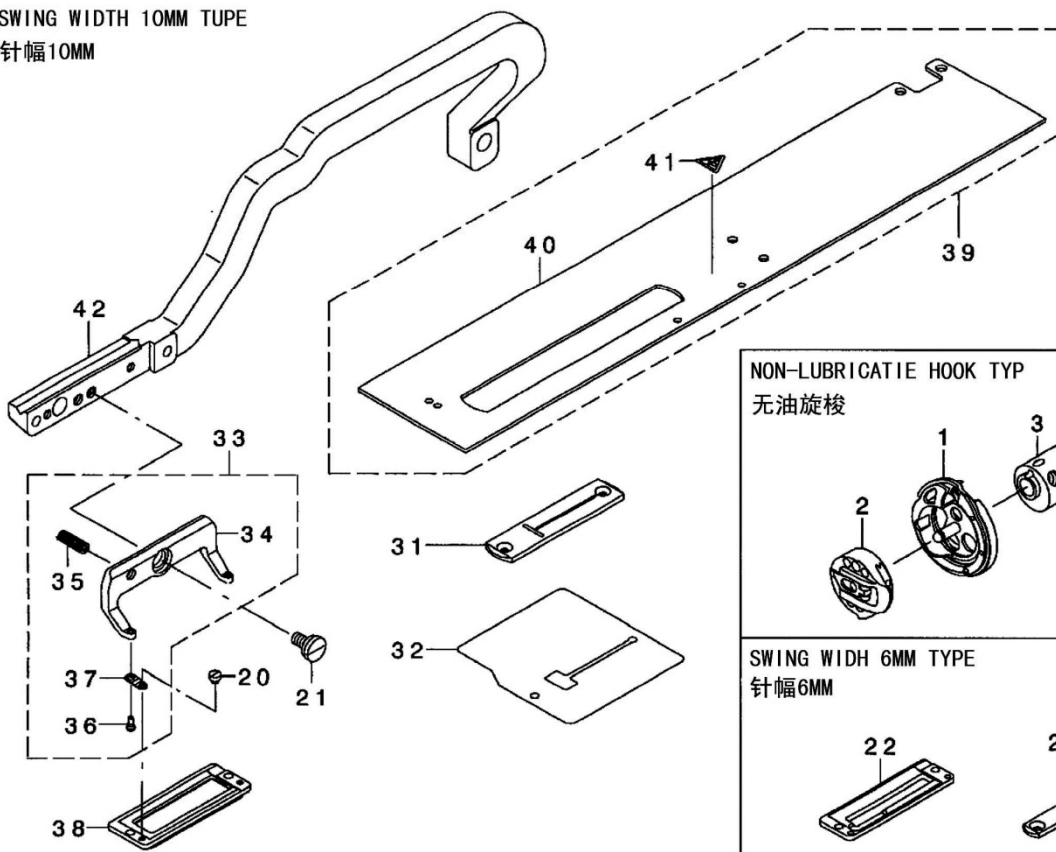

NON-LUBRICATIE HOOK TYP
无油旋梭

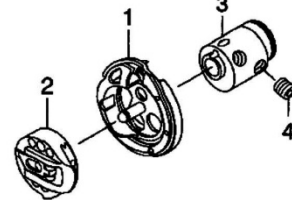

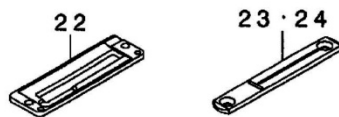

SWING WIDH 6MM TYPE
针幅6MM



P、特殊类型部件/ Special specifications components

参照号	零部件序号	数量	零部件名称	NAME OF PARTS	RM
1	CS79006345	1	旋梭	RP HOOK ASM.	
2	CS79006349	1	梭壳	RP BOBBIN CASE	
3	CS79029603	1	旋梭连接套组件	HOOK SLEEVE	
4	CS08660612	4	螺钉 SM1/4” -40	SCREW, PAN SM SM1/4” -40	
5	CS79006340	1	垫块	WORK CLAMP HOLDER SPACE	
6	CS06040450	3	螺钉 M4X4	SCREW, PAN M4X4	
7	CS79028682	1	剪线板 120B	UTT CLOSE CAM 120B	
8	CS79006342	1	压脚前后送料导向板 120	LIFTING PLATE 120	
9	CS06050800	2	螺钉 M5X8	SCREW, PAN M5X8	
10	CS79006335	1	压脚支架 120MM	WORK CLAMP ARM 120MM	
11	CS79006339	1	送料板 120MM	WORK CLAMP CARRIER 120MM	
12	CS79023252	1	压脚组件 70MM	PRESSER FOOT 70 ASM.	
13	CS01509761	2	压脚弹簧板	PRESSER FITTING PLATE SPRING	
14	CS01512761	1	压脚板座弹簧	PRESSER FKKT HOLDBR SPRING	
15	CS79023203	1	压脚板座 70MM	PRESSER FOOT 70MM	
16	CS01510771	2	压脚弹簧定位销	PRESSER FOOT PI B	
17	CS79023708	1	压脚板 70MM	PRESSER 70	
18	CS79024102	1	压脚板 70MM	PRESSER 70	
19	CS79023401	1	压脚板 70MM	PRESSER 70	
20	CS06060210	6	螺钉 SM3/32” -56	SCREW, PAN SM SM3/32” -56	
21	CS00790203	3	轴位螺钉	SHOULDER SCREW D7. 94 H2	
22	CS79024409	1	压脚板 6M	PRESSER 6M	
23	CS79004351	1	针板 (S6)	THROAT PLATE (S6)	
24	CS79004353	1	针板 (K6)	THROAT PLATE (K6)	
25	CS79008646	1	压脚组件 120MM	ASSY WORK CLAMP CHECK HOLDER 120MM	
26	CS79008638	1	压脚板座弹簧	WORK CLAMP CHECK HOLDBR SPRING	
27	CS01510771	2	压脚弹簧定位销	WORK CLAMP CHECK SPRING SET PI	
28	CS01509761	2	压脚弹簧板	WORK CLAMP CHECK SPRING	
29	CS79008647	1	压脚板座 120MM	WORK CLAMP CHECK HOLDER 120MM	
30	CS79008658	1	压脚板 120MM	WORK CLAMP 120MM	
31	CS79015733	1	针板 (S10)	THROAT PLATE (S10)	
32	CS79015802	1	防油板	OIL SHIELD 10	
33	CS79020010	1	压脚组件 (3-10)	WORK CLAMP HOLDBR (3-10) ASSY	
34	CS79020011	1	压脚板座 (3-10)	WORK CLAMP HOLDBR (3-10)	
35	CS79008638	1	压脚板座弹簧	WORK CLAMP CHECK HOLDBR SPRING	
36	CS01510771	2	压脚弹簧定位销	WORK CLAMP CHECK SPRING SET PI	
37	CS01509761	2	压脚弹簧板	WORK CLAMP CHECK SPRING	
38	CS79017810	1	压脚板 (3S-10)	WORK CLAMP (S3-10)	
39	CS79020014	1	送料板组件	WORK CLAMP CARRIER (10X41) CL	
40	CS79020012	1	送料板	WORK CLAMP CARRIER (10X41)	
41	CS03002000	1	警告标签	ATTENTION SEAL	
42	CS79020013	1	压脚支架 (10X41)	WORK CLAMP ARM (10X41)	

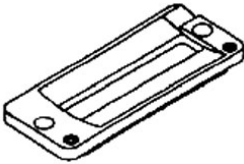
SP、交换部件/ Exchanging parts

		Cloth Cutting knife 切刀片	Presser Foot (Length of cloth Cutting Knife) 压脚板			Presser Foot (Presser Size) 压脚组件
						
		标准 Standard	标准 Standard	专用 For Hoisieri	标准(针幅) Standard (For swing width 6mm)	标准 Standard
inch	mm	Part. no	Part. no	Part. no	Part. no	Part. no
1/4	6.4	CS2702047F	CS01552781 (6.4~19.1mm)	CS01508771 (6.4~19.1mm)	CS79024409 (6.4~31.8mm)	CS01511771 (Type 1)
3/8	9.5	CS2702047K				
7/16	11.1	CS2702047I				
1/2	12.7	CS2702047L				
9/16	14.3	CS2702047V				
5/8	15.9	CS2702047M				
11/16	17.5	CS2702047A				
3/4	19.1	CS2702047N				
7/8	22.2	CS2702047P	CS01552782 (6.4~25.4mm)	CS01508772 (6.4~25.4mm)	CS79024409 (6.4~31.8mm)	CS01511772 (Type 2)
1	25.4	CS2702047Q	CS01552783 (6.4~31.8mm)	CS01508773 (6.4~31.8mm)		CS01511773 (Type 3)
1-1/4	31.8	CS2702047S				